

**PARSUN OUTBOARD ENGINE
SERVICE MANUAL**

F4BM (F5BM)

SUZHOU PARSUN POWER MACHINE CO., LTD.

NOTICE

This manual includes service instructions for F4, F5, and has been prepared by Parsun Power primarily for use by the dealers when performing maintenance and repair to Parsun outboard engines. Before performing maintenance, please read the manual carefully. When performing maintenance and repair to Parsun outboard engines, please use the service procedure and tools recommended by the manual. If you use other service procedure and tools, please follow guidance from experienced maintenance people, to avoid damage to people and outboard engines.

The manual is based on the sample machines that are produced at the time of printing, so the model being actual purchased may differ a little from the descriptions and illustrations given in this manual. If necessary, our company will distribute the manual revision to dealers.

In this Service Manual, particularly important information is distinguished in the following ways. Please read the manual carefully, and perform the instructions correctly and carefully.

WARNING:

Failure to follow WARNING instructions could result in severe injury or death to the machine operator and bystander.

CAUTION:

A CAUTION indicates special precautions that must be taken to avoid damage to the outboard motor.

NOTE:

A NOTE provides key information to make procedures easier or clearer.

The common troubles and solutions are given in the end of the manual, please read carefully. When performing maintenance and repair to Parsun outboard engines, they will help you judge the outboard engine's status quickly and improve the work efficiency.

All rights reserved.

This manual cannot be reproduced or transmitted in any form or by any means without the written approval of our company.

Suzhou Parsun Power Machine Co., Ltd.

INDEX

GENERAL INFORMATION	1
IDENTIFICATION	1
PROPELLER SELECTION	1
EMERGENCY START	1
SAFETY WHILE WORKING	3
DISASSEMBLY AND ASSEMBLY	3
ONE-TIME USE PARTS	4
PRE-DELIVERY CHECK	4
SPECIAL TOOLS AND DETECTION DEVICE	6
EXPLOSIVE DRAWING AND SYMBOL	8
SPECIFICATIONS	9
OUTBOARD ENGINE SPECIFICATIONS	9
MAINTENANCE INFORMATION	10
Power unit	10
Ignition system	11
TIGHTENING TORQUE	11
Specified torque	11
General torque	12
PERIODIC SERVICE	13
MAINTENANCE TIME TABLE	13
FUEL SYSTEM	13
POWER UNIT	14
Engine oil level	14
Changing engine oil	15
Valve clearance	15
Spark plug	16
CONTROL SYSTEM	16
Throttle grip	16
Idling speed	17
Start-in-gear protection	17
LOWER UNIT	18
Gear oil	18
Changing gear oil	18
Lower unit leakage check	19
GENERAL INSPECTION	19
Anode	19
Grease points	19
Cooling water passage	19

RECOIL STARTER	20
NOTICE	20
EXPLOSIVE DRAWING	21
DISASSEMBLING	24
START ROPE REPLACEMENT	24
DISASSEMBLING AND INSPECTION	25
ASSEMBLING	26
INSTALLATION	26
IGNITION SYSTEM	27
NOTICE	27
EXPLOSIVE DRAWING	27
WIRING DIAGRAM	28
SPARK PLUG IGNITION	28
SPARK PLUG CAP	29
FLYWHEEL MAINTENANCE	29
IGNITOR ASS'Y COIL INSPECTION	29
FUEL SYSTEM	30
NOTICE	30
EXPLOSIVE DRAWING	30
FUEL TANK REMOVAL AND INSPECTION	36
OIL SWITCH REMOVAL AND INSPECTION	37
FUEL JOINT REMOVAL AND INSPECTION	37
FUEL PUMP REMOVAL AND INSPECTION	38
INTAKE SYSTEM REMOVAL AND INSPECTION	39
POWER UNIT	40
NOTICE	40
EXPLOSIVE DRAWING	40
SPECIAL TOOLS	49
DISASSEMBLING POWER UNIT FROM OUTBOARD ENGINE . . .	49
DISASSEMBLING AND INSPECTION	49
CYLINDER COVER	50
Disassembling	50
Push rod	50
Valve and valve pipe	50
Valve spring	51
Valve rocker arm	51
Valve pipe replacement	51
Valve seat inspection	51

Valve seat cutting	52
Thermostat	53
CRANKCASE	53
Disassembling	53
Breather	53
Piston	54
Cylinder bore	54
Piston pin diameter	54
Piston ring	54
Camshaft decompressor	54
Crankshaft	55
Oil clearance	55
Valve lifter	55
Oil splash gear	55
Crankshaft bearing	55
Oil seal housing	56
Crankcase and crankcase cover	56
FULL INSTALLATION	56
Piston connecting rod installation	56
Piston ring installation	56
Piston installation	56
Oil seal housing installation	57
Crankshaft installation	57
Camshaft installation	57
Crankcase cover installation	58
UPPER UNIT	58
TOP COWLING	58
Explosive drawing	58
Disassembling and inspection	61
BOTTOM COWLING	61
Explosive drawing	61
Disassembling and inspection	63
STEERING HANDLE	64
Explosive drawing	64
Disassembling and inspection	66
BRACKET	68
Explosive drawing	68
Disassembling and inspection	71
UPPER UNIT	73
Explosive drawing	73

Disassembling and inspection	75
LOWER UNIT	76
WATER PUMP ASSEMBLY	76
Explosive drawing	76
Disassembling and inspection	78
LOWER UNIT	79
Explosive Drawing	79
Disassembling and inspection	83
Propeller shaft and clutch block	84
Clutch block installation	84
Lower casing cover	84
Lower casing cover oil seal and bearing installation	84
Barrel bearing	85
Drive shaft	85
Gear	85
Forward gear bearing	85
Lower unit casing	85
COMMON TROUBLES AND SOLUTIONS	86

GENERAL INFORMATION

IDENTIFICATION

The outboard motor serial number is marked on the label. The label can be found on the bracket left assembly or on the upper part of the bracket swivel. Record your outboard motor serial number in the spaces provided to assist you in ordering spare parts from your Parsun dealer or for reference in case your outboard motor is stolen.

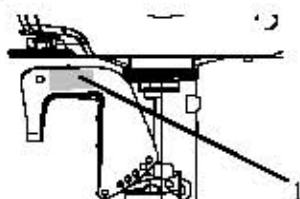

1. Outboard motor serial number location

Serial number as follows:

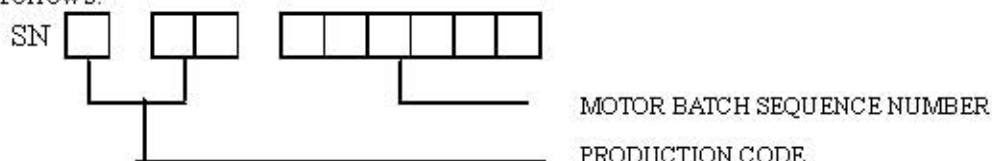

PROPELLER SELECTION

The performance of your outboard motor will be critically affected by your choice of propeller, as an incorrect choice could adversely affect performance.

For a greater boat load and a low engine speed, a smaller-pitch propeller is more suitable. Conversely, a large-pitch propeller is more suitable for a smaller operating load as it enables the correct engine speed to be maintained.

When the engine is running at full throttle position, the suitable propeller should be used according to the engine's RPM and the fuel capability. So the outboard engine can supply the best performance.

Propeller sizes	Material
7 1/4×8	Aluminum alloy
7 1/2×7	
7 1/4×6 1/2	

EMERGENCY START

If the starting device is not working, the engine can be started by emergency start cable.

⚠ WARNING:

- The start program can only be used in emergency and to return to harbor for repairing.
- When you start the engine by emergency start cable, the start-in-gear protection device is not working. So please ensure the shift rod is in NEUTRAL position.
- Please ensure nobody standing behind you in case the cable is pulled out to hurt people.
- After the engine starts up, don't fit the start device or top cowling. Put clothing or other items far away. Don't touch flywheel or other moving parts.
- When starting and operating, don't touch ignition coil, spark plug cap or other electric

parts.

The procedure is as follows:

1. Remove the top cowling.
2. Remove the start-in-gear protection device cable, and remove the chock lever cable.



1. Start-in-gear protection device cable 2. Chock lever cable

3. Demount three bolts and remove starter.

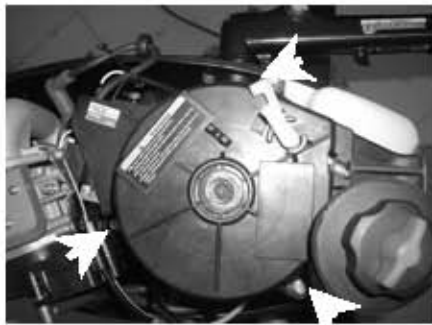

4. Assemble two bolts to fix the fuel tank.



5. Insert the knot of the cable in the notch of flywheel rotor, and wind the cable around flywheel several rounds in clockwise direction.
6. Pull the manual starter handle slowly until you feel resistance.



7. Give a strong pull to start the engine. Repeat if necessary.

SAFETY WHILE WORKING

To prevent the danger or accidents when performing maintenance and repair, and improve the work efficiency, please obey the following safety procedures.

1. FIRE PREVENTION

Gasoline (petrol), lubricant and grease are highly flammable. While working, keep away from heat, sparks and open flames.

2. VENTILATION

Petroleum vapor and engine exhaust gases are violent in toxicity. They are harmful to breathe and deadly if inhaled in large quantities. When test-running an engine indoors, maintain good ventilation.

3. SELF-PROTECTION

Protect your eyes with suitable safety glasses or safety goggles, when drilling, grinding or operating air compressor. Protect hands and feet by wearing protective work clothes, safety gloves and shoes if necessary.

4. LUBRICANTS AND SEALING FLUIDS

When performing maintenance procedures and repair to Parsun outboards, use only products provided or recommended by our Company.

Under normal conditions of use, there should be no hazards from the use of the lubricants mentioned in this manual, but safety is all-important, and by adopting good safety practices, any risk is minimized.

A summary of the most important precautions is as follows:

- ① To protect the skin, the application of a suitable barrier cream to the hands before working is recommended.
- ② Clothing which has become contaminated with lubricants should be changed as soon as practicable, and washed before further use.
- ③ Avoid skin contact with lubricants.
- ④ Hands and any other part of the body which have been in contact with lubricants or lubricant-contaminated clothing, should be thoroughly washed with hot water and soap as soon as practicable.
- ⑤ A supply of clean lint-free cloths should be available for wiping run-off lubricants or grease.

5. GOOD WORKING PRACTICES

- ① Follow the tightening torque instruction. When tightening bolts, nuts and screws, tighten the large sizes first, and tighten inner-positioned fixings before outer-positioned ones.
- ② Use the recommended special tools to protect parts from damage. Use the right tool in the right manner.

DISASSEMBLY AND ASSEMBLY

When disassembly and assembly, please follow the following principles:

1. Use special tools when disassembling and assembling.
2. Clean dirt before disassembling the parts.
3. Oil the contact surfaces of moving parts before assembly.
4. Install bearing with the manufacturer's markings on the side exposed to view and liberally oil the bearing.
5. When installing oil seals, apply a light coating of water-resistant grease to the ledge and outside diameter.
6. After assembly, check if the moving parts operate normally.

ONE-TIME USE PARTS

One-time use parts are gasket, oil seal, O-ring, cotter pin and spring, ring, and etc.. When re-assembling outboard engine, you must change the one-time use parts.

PRE-DELIVERY CHECK

To ensure the using, please inspect the following before delivery.

1. CHECKING FUEL SYSTEM

Check if the fuel pipe is connected firmly, and if the fuel tank is filled with fuel.

CAUTION:

Do not use pre-mixed fuel for this 4-stroke outboard engine.

2. CHECKING OIL LEVEL

Ⓐ Check the engine oil level

Remove oil cap, check engine oil level.

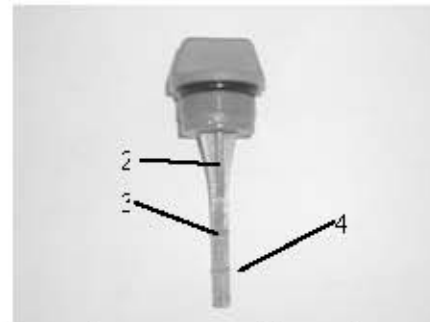

1. Oil cap 2. Oil rule 3. High position mark 4. Low position mark

Ensure the oil level between the marks of upper and lower. If above upper level, drain engine oil; if below lower mark, add engine oil up to upper level.

Ⓑ Check the gear oil level

Remove the oil level plug. Check if the gear oil overflows at the oil level checking hole. If so, install the oil level plug and tighten it according to specified torque. Otherwise please add gear oil.



1. Oil level plug

3. CHECK STEERING SYSTEM

Check if steering is stable.

Check if steering friction is adjusted correctly.

Turn clamp handle screw clockwise to increase resistance.

Turn clamp handle screw counter clockwise to lower resistance.

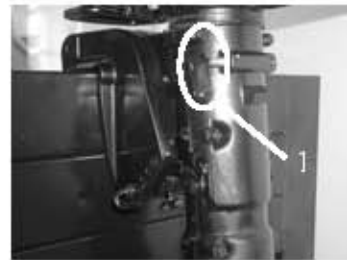

1. Clamp handle screw

4. CHECK SHIFT LEVER AND THROTTLE

Check if the shift lever is operated smoothly.

Check if the throttle grip is turned smoothly from full closed position to full open position.

5. CHECK ENGINE STOP SWITCH ASSY

Check if the engine stops when pushing the engine stop switch assembly or pulling out the stopper hang rope.

6. CHECK COOLING WATER CHECKING HOLE

When the engine is running, check if cooling water overflows at the cooling water checking hole.



1. Cooling water checking hole

7. BREAKING-IN RUNNING

① Initial 1 hour: operate the engine at 2000 r/min or about a half throttle.

② The second hour: operate the engine at 3000 r/min or about 3/4 throttle.

③ The following 8 hours: operate the engine at full throttle continuously. Each operation time doesn't exceed 5 minutes.

8. INSPECTION AFTER BREAKING-IN RUNNING

① Check if gear oil contains water.

② Check if the fuel line leaks.

③ After breaking-in running, operate the engine at idling speed. Use cleaning tool to wash

over the cooling water passage by fresh water.

9. After breaking-in running, inspect idling speed.

- ① Preheating engine for 5 minutes.
- ② Using the tachometer to measure idling speed RPM.
If out of specification, adjust it.
Idling speed: 1450~1550 r/min
- ③ Turn the throttle stop screw clockwise or counter clockwise until the specified idling speed is attained.
- ④ After adjusting idling speed, picking up RPM several times to check the engine's stability.



SPECIAL TOOLS AND DETECTION DEVICE

When performing maintenance and repair, you need to use all kinds of special tools and detection device. The use of correct tools will improve the work efficiency and avoid of the damage to the people and outboard engines.

SPECIAL TOOLS:



Piston slider



Flywheel holder and puller

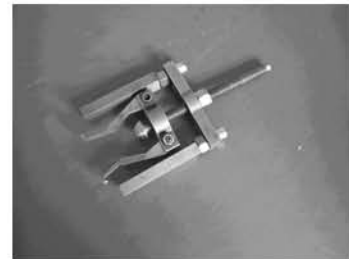

Bearing puller



Valve spring compressor



Housing bearing installer



Lower casing cover bearing installer



Oil seal installer tool



Housing oil seal installer

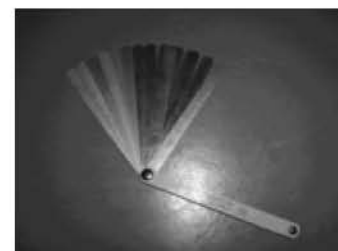

Space gage



Barrel bearing with guard board installer tool



Lower casing bracket and barrel bearing without guard board installer tool



Lower casing bracket and drive shaft oil seal installer tool

DETECTION DEVICE:



Digital tachometer



Digital circuit tester



Peak voltage adaptor

EXPLOSIVE DRAWING AND SYMBOL

EXPLOSIVE DRAWING

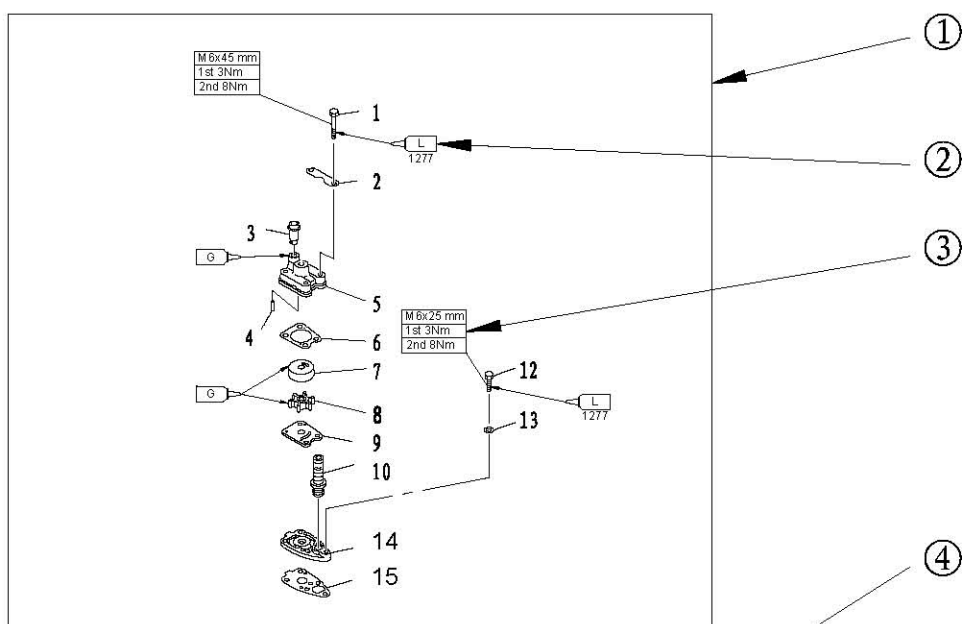

参照号码 SN.	零件编号 PART NO.	零件名称 DESCRIPTION	数量 QTY	备注 REMARKS
1	GB/T5782-2000	六角头螺栓M6 × 45 HEXAGON BOLT	4	
2	P4-03000020	泵壳固定板 PLATE, WATER PUMP FIXED	2	
3	P4-03000021	泵壳橡胶管 RUBBER TUBE, WATER PUMP	1	
4	P4-03000013	水泵座定位销 PIN, WATER PUMP	2	
5	P4-03000019	水泵壳 HOUSING, WATER PUMP	1	
6	P4-03000018	泵壳密封垫 GASKET, WATER PUMP COVER	1	
7	P4-03000017	水泵内壳 COVER, INNER WATER PUMP	1	
8	P4-03060000	水泵叶轮 IMPELLER, WATER PUMP	1	
9	P4-03000015	外档板 OUT PLATE	1	
10	P4-03000014	黄蜡橡胶护套 (含弹簧) RUBBER JACKET, SHIRT ROD	1	

- ① Parts explosive drawing
- ② Oil, fluid sealant or locking substance daubing point
- ③ Screw specification and specified torque
- ④ Spare parts details

SYMBOL

Daub engine oil	Daub waterproof grease	Daub screw locking substance 1277	Daub screw locking substance 1243

SPECIFICATIONS

OUTBOARD ENGINE SPECIFICATIONS

Item		Description		Item		Description			
Dimension	Overall length		717mm		Power Unit	Starting enrichment		Choke valve	
	Overall width		361mm			Spark plug		BPR7HS	
	Overall height	S	1029mm			Exhaust system		Under water	
		L	1156mm			Lubrication system		Splash lubrication	
Weight	S		24.5kg		Fuel and Oil	Fuel type		Unleaded regular gasoline	
	L		25.5kg			Fuel standard		PON86、RON91	
Performance	Max output		2.9Kw(4hp)@4500r/min			Fuel tank capacity		1.3L	
			3.6Kw(5hp)@5000r/min			Recommended engine oil		API SE, SF, SE-SF, SG-CD SAE 10W30, 10W40	
	Full throttle operation		4000~5000r/min			Engine oil quantity		0.5L	
	Max fuel consumption		1.6L/h@5000r/min			Recommended gear oil		Hypoid gear oil SAE # 90	
	Idle speed (Neutral)		1500±50 r/min			Gear oil quantity		100 mm ³	
Power Unit	Type		4 stroke, OHV			Bracket	Tilt angle		4°, 8°, 12°, 16°, 20°
	Number of cylinders		1				Tilt-up angle		76°
	Displacement		112cm ³				Shallow water cruising angle		30°, 42°, 54°
	Bore×Stroke		59mm×41mm		Steering angle		360°		
	Compression ratio		8.4		Drive Unit		Gear positions		F-N-R
	Compression pressure		660kPa			Gear ratio		2.08	
	Number of carburetors		1			Gear type		Bevel gear	
	Control system		Tiller control			Propeller direction		Clockwise	
	Starting system		Recoil starter			Propeller drive system		Spline	
	Ignition control system		T.C.I						

MAINTENANCE INFORMATION

Power Unit

Item		Description	Item		Description	
Cylinder Head	Warp limit	0.1mm	Valve	Valve clearance (cold)	Intake	0.10±0.02mm
					Exhaust	0.10±0.02mm
Cylinder	Bore	59.00~59.02mm		Face width	Intake	1.84~2.26mm
	Wear limit	59.1mm			Exhaust	1.84~2.26mm
	Taper limit	0.08mm		Seat width	Intake	0.6~0.8mm
	Out of round limit	0.05mm			Exhaust	0.6~0.8mm
Piston	Piston diameter	58.950~58.965mm		Margin thickness	Intake	0.7mm
	Measuring point height	10mm (from the bottom of piston)			Exhaust	1.0mm
	Piston-to-cylinder clearance	0.035~0.065mm		Head diameter	Intake	23.9~24.1mm
	Pin boss inside diameter	13.009~13.017mm			Exhaust	21.9~22.1mm
Piston pin outside diameter		12.995~13.000mm		Stem outside diameter	Intake	5.475~5.490mm
					Exhaust	5.460~5.475mm
Piston ring	Top ring	Thickness	1.5mm	Guide inside diameter	Intake	5.500~5.512mm
		Breadth	2.6mm		Exhaust	
		End gap	0.10~0.20mm	Stem to guide clearance	Intake	0.010~0.037mm
		Wear limit	0.40mm		Exhaust	0.025~0.052mm
		Side clearance	0.04~0.08mm	Push rod runout limit		0.5mm
	2nd ring	Thickness	1.5mm	Valve spring	Free length	35.0mm
		Breadth	2.6mm		Free length limit	34.0mm
		End gap	0.25~0.40mm		Tilt limit	1.2mm
		Wear limit	0.60mm	Connecting rod	Small end inside diameter.	13.006~13.02mm
	Side clearance	0.02~0.06mm	Big end oil clearance		0.016~0.046mm	
	Oil ring	Thickness	2.5mm	Crankshaft	Crankshaft width	64.4~64.5mm
		Breadth	2.6mm		Big end side clearance	0.2~0.6mm
End gap		0.20~0.70mm	Round limit		0.03mm	
Wear limit		0.90mm				

Cont'd

Item		Description	Item	Description	
Camshaft	Height	Intake	Thermostat	Valve opening temperature	58~62°C
		Exhaust		26.532~26.623mm	Full-open temperature
	Round diameter	21.950~22.050mm		Valve lift	3mm
	Journal diameter	14.966~14.984mm	Fuel pump	Discharge	8L/h
	Camshaft round limit	0.03mm		Pressure	50kPa
Valve lifter outside diameter	7.978~7.987mm	Plunger stroke		1.8~2.2mm	

Ignition system

Item	Description	Item	Description	
Ignition timing	BTDC28° ~32°	Spark plug gap	0.6~0.7mm	
T.C.I system output peak voltage	130V	Ignitor ass'y resistance	Primary coil	0.7~0.96 Ω
T.C.I air gap	0.4~0.6mm		Secondary coil	5.8~7.0K Ω

TIGHTENING TORQUE

Specified torque

Part to be tightened		Part name	Thread size	Quantity	Torque	
Power unit	Oil drain	Bolt	M8	1	20Nm	
	Spark plug	—	M14	1	25 Nm	
	Recoil starter	Bolt	M6	3	8 Nm	
	Flywheel rotor ass'y	Nut	M10	1	44 Nm	
	Carburetor	Bolt	M6	2	8 Nm	
	Intake manifold	Bolt	M6	2	8 Nm	
	Cylinder head cover	Bolt	M6	4	11 Nm	
	Cylinder head	1st tightening	Bolt	M8	4	15 Nm
		2nd tightening				30 Nm
		1st tightening	Bolt	M6	1	6 Nm
		2nd tightening				11 Nm
	Rocker arm screw bolt	Bolt	M6	2	10 Nm	
	Locknut (rocker arm)	Nut	M6x0.75	2	10 Nm	
	Oil seal housing	Bolt	M8	1	18 Nm	
	Power unit mounting	Bolt	M6	7	8 Nm	
	Thermostat cover	Bolt	M6	3	8 Nm	
Breather cover	Bolt	M6	3	8 Nm		
Crankcase	1st tightening	Bolt	M8	7	10 Nm	
	2nd tightening				22 Nm	

Cont'd

Part to be tightened		Part name	Thread size	Quantity	Torque		
Power unit	Connecting rod		Bolt	M7	2	12 Nm	
	Oil splash gear unit		Bolt	M6	1	8 Nm	
Lower unit	Lower unit mounting	1st tightening	Bolt	M6	2	3 Nm	
		2nd tightening				8 Nm	
	Lower unit housing cover	1st tightening	Bolt	M6	2	6Nm	
		2nd tightening				11 Nm	
	Anode	1st tightening	Bolt	M6	1	3 Nm	
		2nd tightening				8 Nm	
	Water pump housing	1st tightening	Bolt	M6	4	3 Nm	
		2nd tightening				8 Nm	
	Water pump base	1st tightening	Bolt	M6	1	3 Nm	
		2nd tightening				8 Nm	
	Upper Unit	Steering handle mounting		Bolt	M8	1	18 Nm
		Shift lever bracket		Bolt	M6	1	4.5 Nm
Bracket fixed cover		1st tightening	Bolt	M6	2	3 Nm	
		2nd tightening				8 Nm	
Tilt lock plate		1st tightening	Nut	M6	2	3 Nm	
		2nd tightening				8 Nm	
Swivel bracket		1st tightening	Nut	M6	6	3 Nm	
		2nd tightening				8 Nm	
Clamp bracket		Nut	M8	1	13 Nm		
Ignitor ass'y		Bolt	M6	2	8Nm		

General torque

Nut (a)	Bolt (b)	Torque
8mm	M5	5Nm
10mm	M6	8 Nm
12mm	M8	18 Nm
14mm	M10	36 Nm
17mm	M12	43 Nm

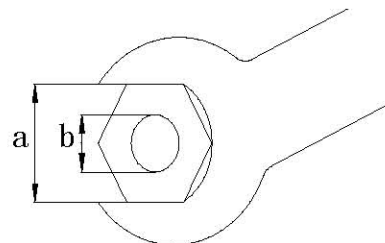

PERIODIC SERVICE MAINTENANCE TIME TABLE

Items	Contents	Initial maintenace		General maintenance period	
		10 hours (1 month)	50 hours (3 months)	100 hours (6 months)	200 hours (1 year)
Anode	Inspection/replacement		○	○	
Spark plug	Cleaning/adjustment /replacement	○	○	○	
Grease points	Greasing		○		
Bolts and nuts	Inspection	○		○	
Fuel tank and fuel line	Inspection			○	
Fuel filter	Inspection/replacement	○	○	○	
Fuel cock	Inspection/replacement	○		○	
Carburetor	Inspection/replacement	○		○	
Throttle cable	Inspection/replacement	○		○	
Idling speed	Inspection/ adjustment	○		○	
Start-in-gear projection	Inspection/ adjustment	○		○	
Engine oil	Replacement	○		○	
Valve cleanrance	Inspection/ adjustment	○		○	
Ignition timing	Inspection	○		○	
T.C.I air gap	Inspection/ adjustment	○		○	
Thermostat	Inspection				○
Cooling water passage	Inspection/Cleaning		○	○	
Gear oil	Replacement	○		○	
Water pump	Inspection			○	
Propeller	Inspection/replacement		○	○	

CAUTION:

After running the outboard engine in salt water, waste water or mud water, wash over the engine by fresh water immediately.

If using leaded gasoline frequently, check the valve and components each 100 hours.

FUEL SYSTEM

1. CHECK FUEL TANK, CARBURETOR, FUEL PUMP AND FUEL PIPE

Check if fuel tank, carburetor, fuel pump and fuel pipe are damaged or leaked.

Replace if necessary.

Check if the fuel filter on the tank is dirty. Clean dirt or replace it if necessary.

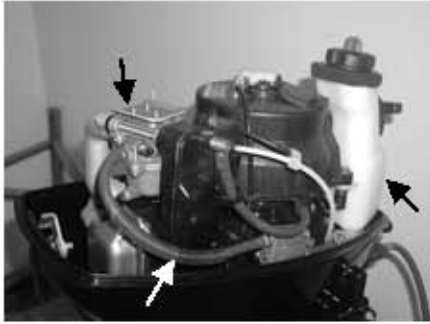

2. CHECK FUEL COCK AND FUEL JOINT

Check if fuel cock and fuel joint are cracked, damaged or leaking.
Replace if necessary.

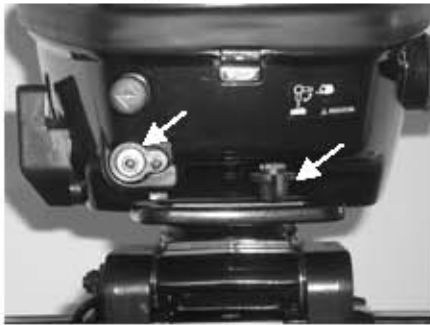

3. CHECK FUEL FILTER

Check if fuel filter is cracked, damaged or has dirt inside.
If so, replace it.



CAUTION:

**The arrow mark of the fuel filter must face toward the fuel pump.
Clean the spilled oil.**

POWER UNIT

Engine oil level

a) Remove oil level plug, check engine oil level, if between the following marks of the upper and lower.

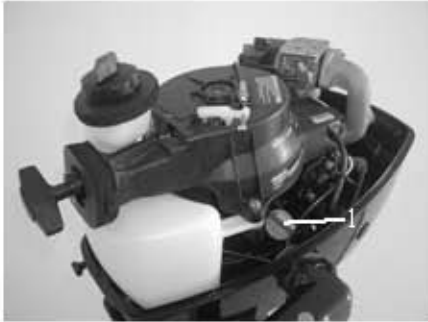

1. Oil level plug 2. Oil rule 3. High position mark 4. Low position mark

b) If above the upper mark, drain the engine oil; if below lower mark, add engine oil up to upper mark.

CAUTION:

Run the engine and then turn it off, wait for several minutes, and check the engine oil level by the oil rule again.

If the engine oil still not within the proper level, add/drain as needed.

Changing engine oil

1. Remove oil level plug, drain plug with washer and gasket, drain off the engine oil



2. Install new gasket and washer; install drain plug.

3. Fill engine oil into the crankcase through oil filler hole.

Engine oil quantity: 0.5L

Oil type: API SE, SF, SE-SF, SG-CD SAE 10W30, 10W40

4. Install oil level plug.

5. Check engine oil level.

Valve clearance

CAUTION:

Rotate the flywheel clockwise so that rocker arm is in free position, before adjusting valve clearance (Dead point position on compression stroke).

1. Remove stopper hang rope from engine stop switch assy.

Remove spark plug cap from spark plug.

2. Remove cylinder head cover
3. Use feeler gauge to measure the clearance between rocker arm and valve rod top: if out of specification, adjust.

Valve clearance (cold position):

Inlet valve: $0.10 \pm 0.02 \text{mm}$

Outlet valve: $0.10 \pm 0.02 \text{mm}$

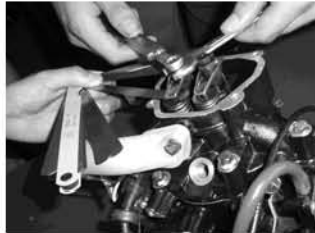

Spark plug

1. Remove spark plug cap and spark plug.
2. Clean off carbon build-up on the electrodes.
3. Check if the electrodes are corroded or have deposit, or if the washer is damaged.
If necessary, change the spark plug.
Spark plug type: BPR7HS
4. Inspect if the spark plug gap is within specification. If necessary, change the spark plug.

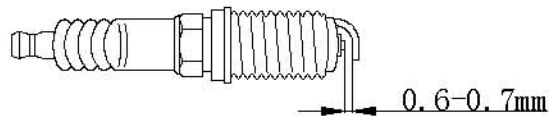

5. Install spark plug. Use spark plug spanner to tighten it according to specified torque.
Specified torque: 25 Nm

CONTROL SYSTEM

Throttle grip

1. Turn the throttle grip to fully closed position.
2. Check if the throttle cable is slack and if the throttle lever touches the throttle stop screw.
3. Loosen throttle cable stopper screw, adjust throttle cable position, and tighten throttle cable stop screw.

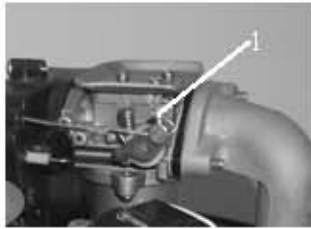

1. throttle cable stop screw

Idling speed

Check idling speed, and adjust it if necessary.

1. Preheat engine for 5 minutes.
2. Attach the tachometer to the spark plug wire to measure idling speed RPM. If out of specification, adjust it.

Idling speed: 1450~1550 r/min



3. Turn the throttle stop screw clockwise or counter clockwise, until the specified idling speed is attained.

NOTE:

Turning clockwise to increase idling speed.

Turning counter clockwise to decrease idling speed.

CAUTION:

Before adjusting the idling speed, the throttle cable slack should be properly adjusted. After adjusting the idling speed, if necessary you can adjust the throttle cable again.

Start-in-gear protection

Set the shift lever in neutral, and check if the triangle marking of the detent aligns with the triangle marking of the starter. If necessary, adjust the adjusting nut on the tightwire of the detent.

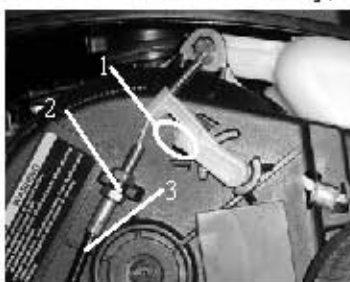

1. Triangle marking 2. Adjusting nut 3. Tightwire ass'y, detent

LOWER UNIT

Gear oil

Check gear oil level:

Remove the oil level plug. If the gear oil overflows at the oil level checking hole, the oil volume added is correct; otherwise please add gear oil.



1. Oil level plug

Changing gear oil

1. Hold the outboard engine in an upright position.
2. Place a container under the drain plug.
3. Remove the drain plug, the oil level plug, and then drain the gear oil.

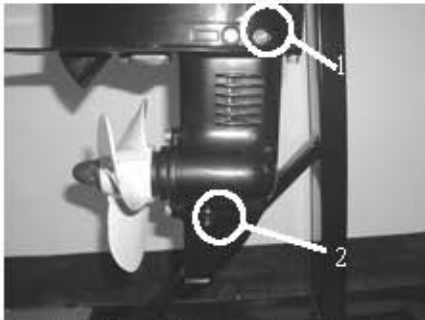

1. Oil level plug 2. Drain plug

4. Add gear oil through the drain plug using pressure filling device.
5. When gear oil overflows at the oil level checking hole, install the oil level plug.
6. Install the drain plug, then clean overflowing gear oil.

NOTE:

Check the drained gear oil.

If the gear oil is milky, please check the oil seal. If necessary, replace the oil seal.

If the gear oil contains metal chippings, please check the gear and bearing.

CAUTION:

Must change drain plug washer each time.

Lower unit leakage check

Connecting the leakage tester to the oil level checking hole to check the lower unit leakage. If the pressure drops (pressure: 1kg/cm²), inspect the oil seal and components.

GENERAL INSPECTION

Anode

Inspect lower unit anode and engine anode (on the thermostat cover). Clean the greasy dirt and scales. If wear or damage is above 1/2, replace the anode.

CAUTION:

Cannot grease or paint the anode, or it will not operate properly.

Grease points

1. Refer the illustration for greasing points, paint the water resistant grease.

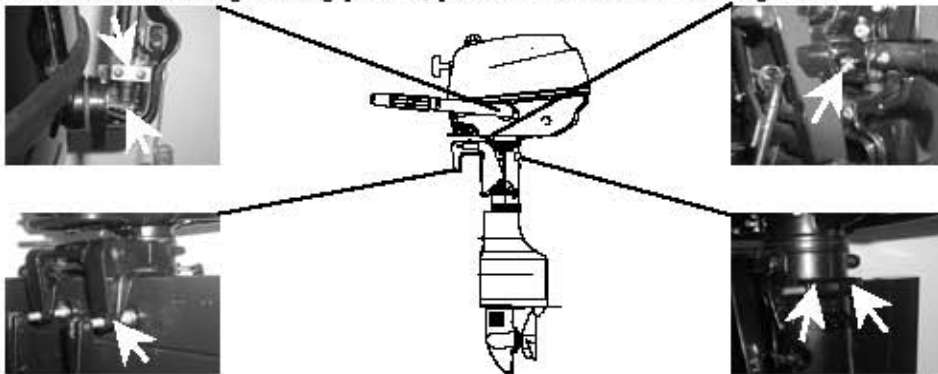

2. Paint anti-corrosion grease on the propeller shaft.



Cooling water passage

1. Inspect cooling water passage
If blocked, clean it.

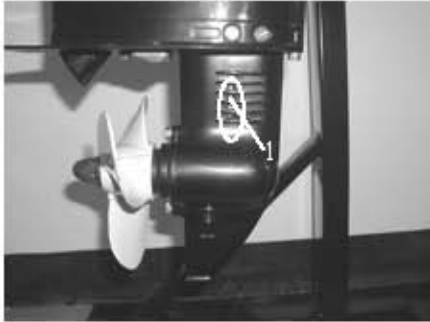

Cooling water passage inlet

2. Place the outboard engine in the water and ensure the water level is above the anti-vortex plate, then start the engine.
3. Check if water overflows at the cooling water checking hole. If there is no flow or intermittent flow, check the cooling water passage.

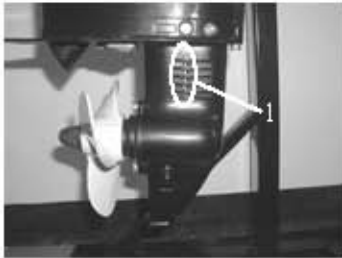

1. Cooling water inlet



2. Cooling water checking hole

RECOIL STARTER

NOTICE

When you service, please wear safety glasses and gloves. Please remove spark plug cap and stopper hang rope from stop switch assy, in case of the accidental start of the engine.

EXPLOSIVE DRAWING

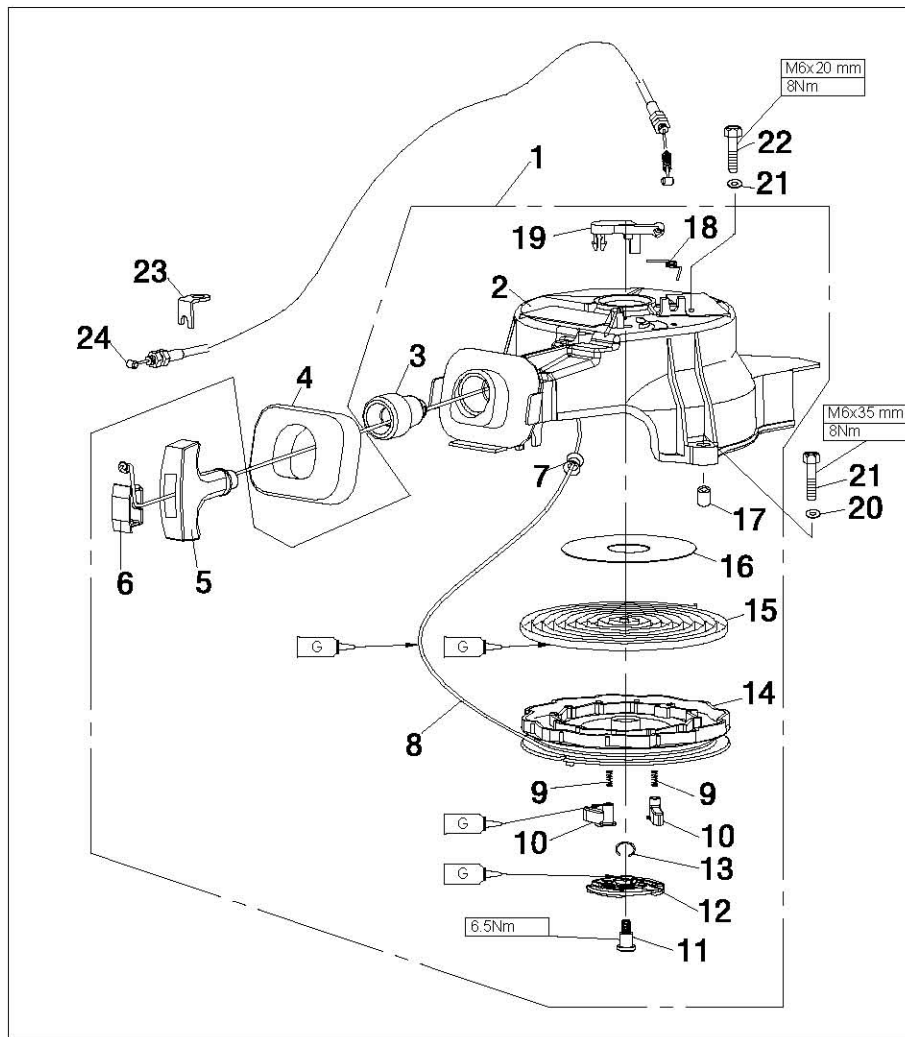

参照号码 SN.	零件编号 PART NO.	零件名称 DESCRIPTION	数量 QTY	备注 REMARKS
1	F4-04130000	起动机组件 STARTER ASSY	1	
2	F4-04130001	起动机外壳 CASE, STARTER	1	
3	F4-04130012	起动机绳导向器 GUIDE, ROPE	1	
4	F4-04130018	起动机减震块 SEAL, RUBBER	1	
5	F4-04130101	起动手柄 HANDLE, STARTER	1	
6	F4-04130102	起动手柄盖 COVER	1	
7	F4-04130013	起动机绳导管 MEATUS, START ROPE	1	
8	F4-04130011	起动机绳 WIRE, STARTER	1	
9	F4-04130004	卡瓣弹簧 SPRING, DRIVE	2	
10	F4-04130003	卡瓣 PAWL, DRIVE	2	

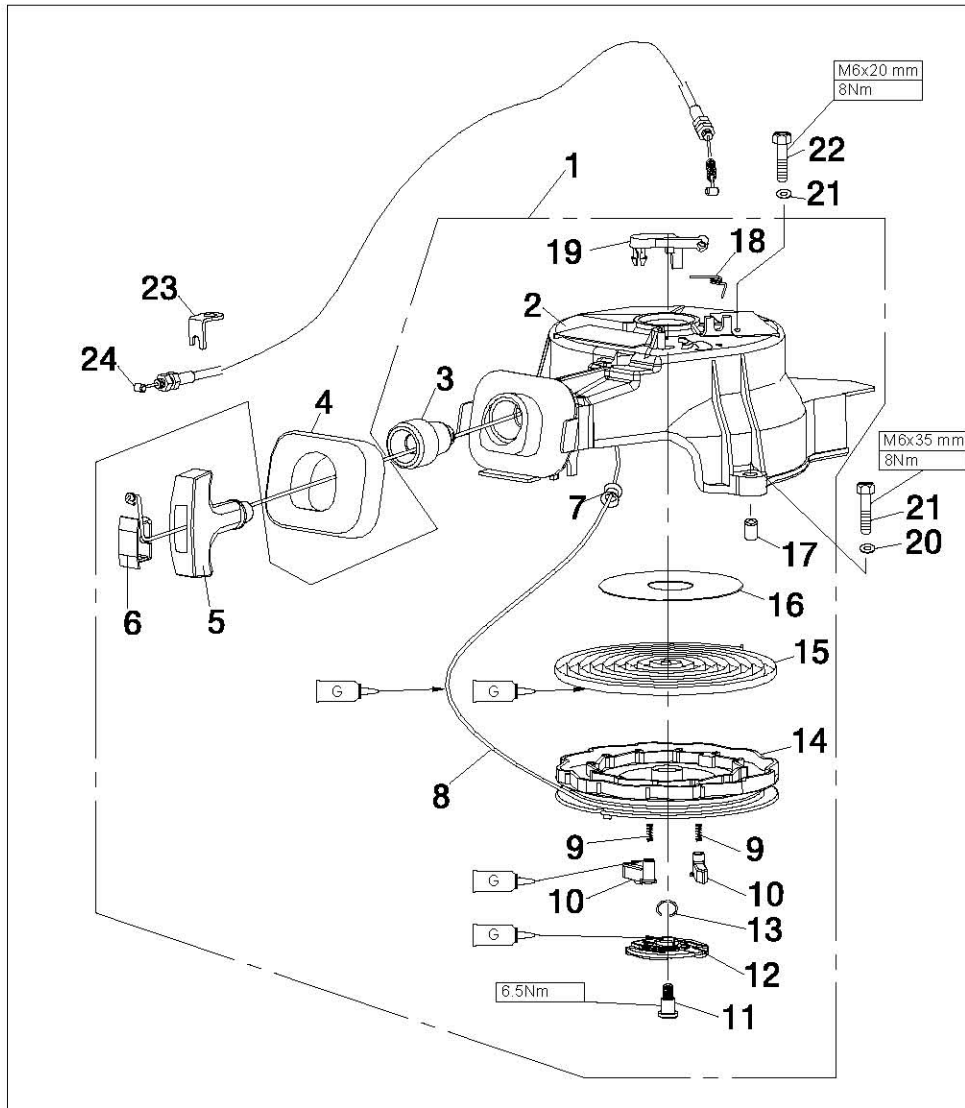

参照号码 SN.	零件编号 PART NO.	零件名称 DESCRIPTION	数量 QTY	备注 REMARKS
11	F4-04130008	起动压板螺钉 BOLT, STARTER	1	
12	F4-04130006	起动压板 PLATE, PRELL	1	
13	F4-04130007	起动压板夹簧 SPRING, PLATE	1	
14	F4-04130019	起动轮 DRULL, SHEAVE	1	
15	F4-04130005	涡形弹簧 SPRING, VOLUTE	1	
16	F4-04130014	起动轮减磨片 WASHER, THRUST	1	
17	F4-04130002	起动器外壳衬管 BUSHING, STARTER CASING	1	
18	F4-04130010	制动器扭簧 WREST SPRING, DETENT	1	
19	F4-04130009	制动器 DETENT	1	
20	GB/T97.1-85	平垫圈 6 WASHER, THRUST	3	

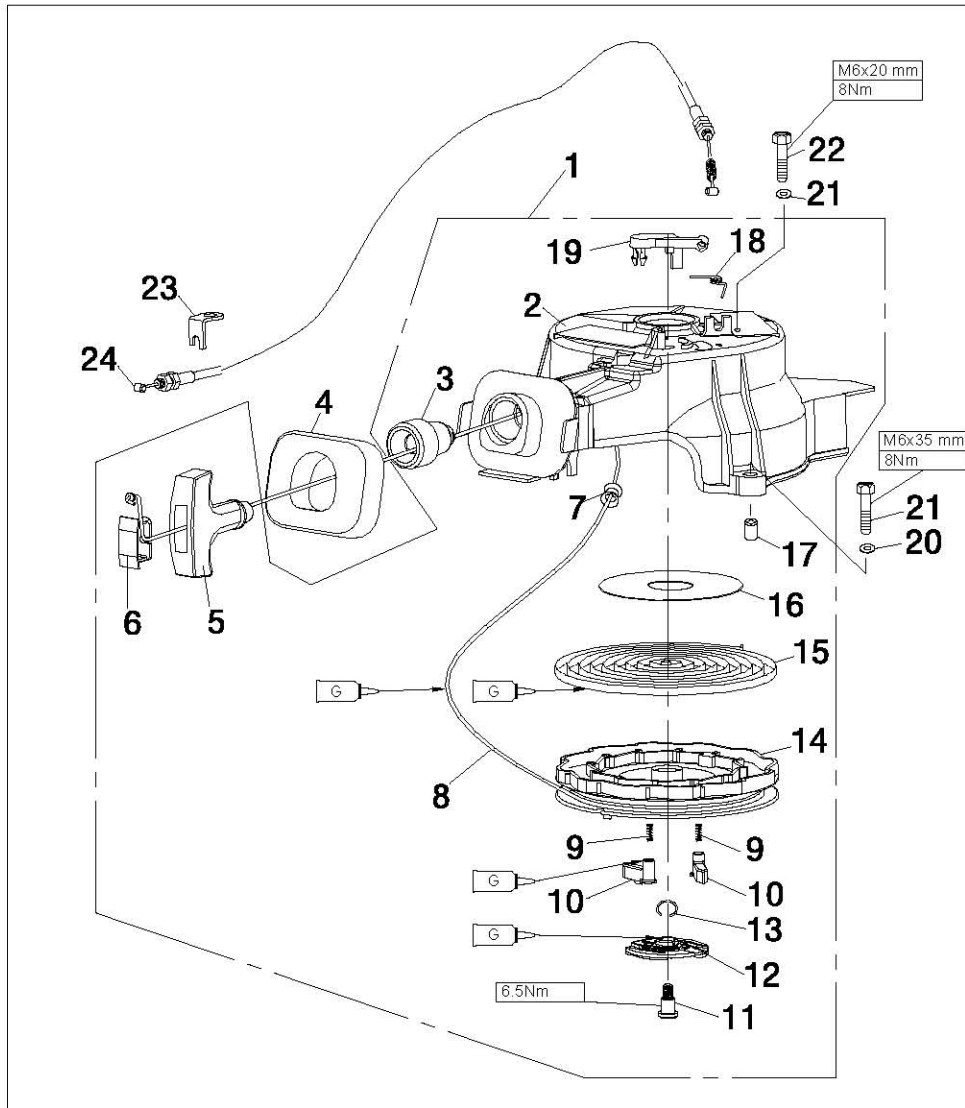

参照号码 SN.	零件编号 PART NO.	零件名称 DESCRIPTION	数量 QTY	备注 REMARKS
21	GB/T5783-2000	六角头螺栓M6x35 BOLT, HEXAGON	2	
22	GB/T5783-2000	六角头螺栓M6x20 BOLT, HEXAGON	1	
23	F4-04000005	钢索固定架 FIXED PLATE, TIGHTWIRE	1	
24	F4-02000013	制动器钢索组件 TIGHTWIRE ASSY, DBTENT	1	

DISASSEMBLING

1. Open the top cowling
2. Screw loosely the adjusting nut of the dent tightwire.

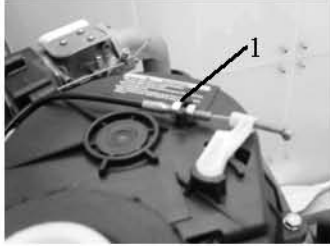

1. Adjusting nut

3. Remove the tightwire from the detent.
4. Remove the starter fixing bolt, and remove the starter.

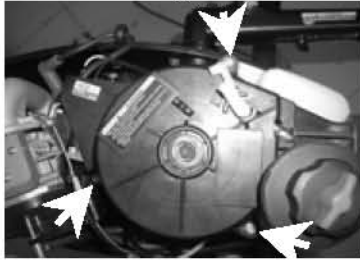

STARTER ROPE REPLACEMENT

1. Pull the starter rope out, and insert it in the notch of the sheave drum. Turn the sheave drum clockwise until the volute spring is free.

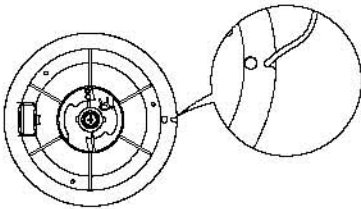

2. Pull the starter rope completely.
3. Remove the starter handle cover from the starter handle, and remove the starter rope. Untie the knot at the end of the starter rope.
4. Pull out the starter rope completely.
5. Insert the new starter rope into the starter assembly, and fix the rope onto the sheave drum and starter handle. At the end of the rope tie a knot as shown.

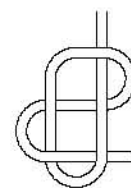

6. Insert the start rope in the notch of the sheave drum and turn the sheave drum several rounds in counter clockwise direction.
7. Pull the starter handle many times to check if the sheave drum rotates stably. If necessary, repeat step 6 and step 7.

DISASSEMBLING AND INSPECTION

1. Remove the start rope.
2. Remove starter bolt, and remove press plate.
3. Remove the sheave drum

WARNING

Uninstall the sheave drum carefully, to ensure that the volute spring does not pop out to hurt people.

4. Remove the volute spring.
5. Remove the detent and detent wrest spring.
6. Inspect if the detent is cracked, worn or damaged. If necessary, replace it.

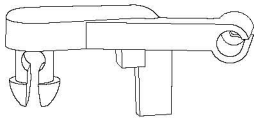

7. Check if the drive pawl is cracked, worn or damaged. If necessary, replace it.

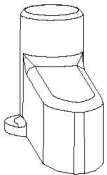

8. Inspect if the drive spring is broken, cranked or damaged. If necessary, replace it.



9. Check if the volute spring is broken, cranked or damaged. If necessary, replace it.

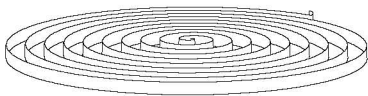

ASSEMBLING

Reverse the steps of disassembling.

INSTALLATION

1. Put starter onto the power unit.
2. Screw the hexagon bolt, and tighten it according to the specified torque.
3. Install the detent tightwire.
4. Adjust the adjusting nut on the tightwire of the dent, and align the triangle marking of the dent with the triangle marking of the starter case.

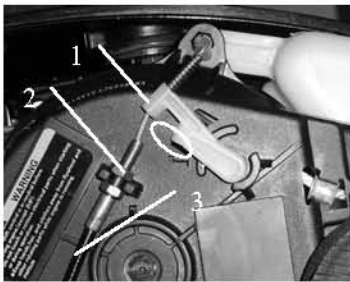

1. Triangle mark
2. Adjusting nut
3. Detent tightwire

IGNITION SYSTEM

NOTICE

When checking and repairing the ignition system, keep your hand, clothes, hair or personal belongings away from the rotating flywheel.

Check ignition coil on insulated working table, to prevent electricity leak and electroshock.

Don't touch the ignition coil or spark plug when the engine is running, to avoid electroshock. Keep the wires away from the rotating flywheel, to prevent the wire from being cut, or the insulating layer of the wire from being worn.

When replacing fixing parts such as nuts and bolts, only parts from original manufacturer or parts made of same material and with strength can be used. Parts must be tightened according to the specified torques.

EXPLOSIVE DRAWING

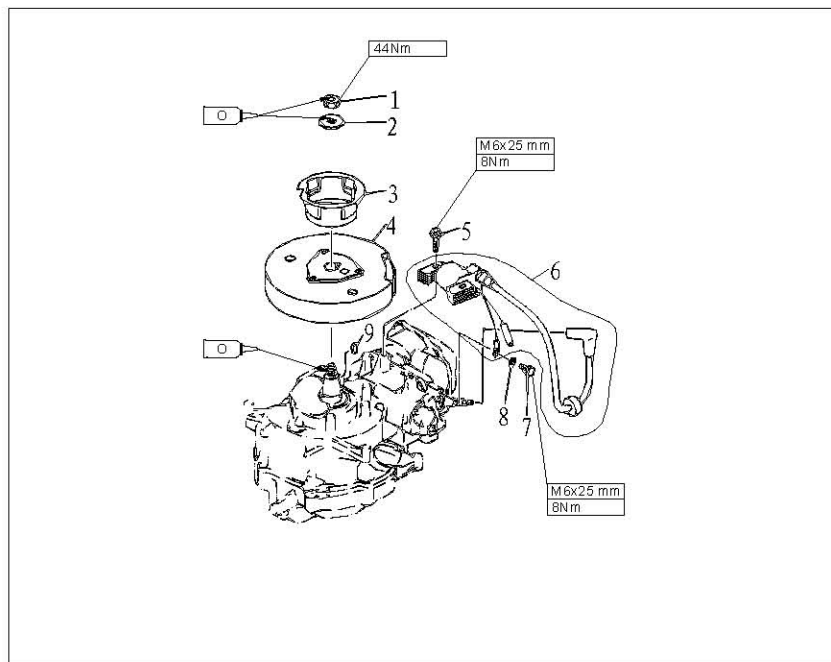

参照号码 SN.	零件编号 PART NO.	零件名称 DESCRIPTION	数量 QTY	备注 REMARKS
1	GB/T6171-86	六角螺母M10x1.25 NUT	1	
2	P4-0400021	飞轮垫圈 WASHER	1	
3	P4-0400020	起动轴套 PULLEY, STANTER	2	
4	P4-04100000	飞轮组件 FLY WHEEL	1	
5	GB/T5782-2000	六角头螺栓M6x25 BOLT	2	
6	P4-0400038	点火线圈组件 IGNITION WINDING ASSY	1	
7	GB/T5783-2000	六角头螺栓M6x10 BOLT	1	
8	GB/T97.1-85	平垫圈6 WASHER, PLATB6	3	
9	P4-0400019	半圆键 KEY	1	

WIRING DIAGRAM

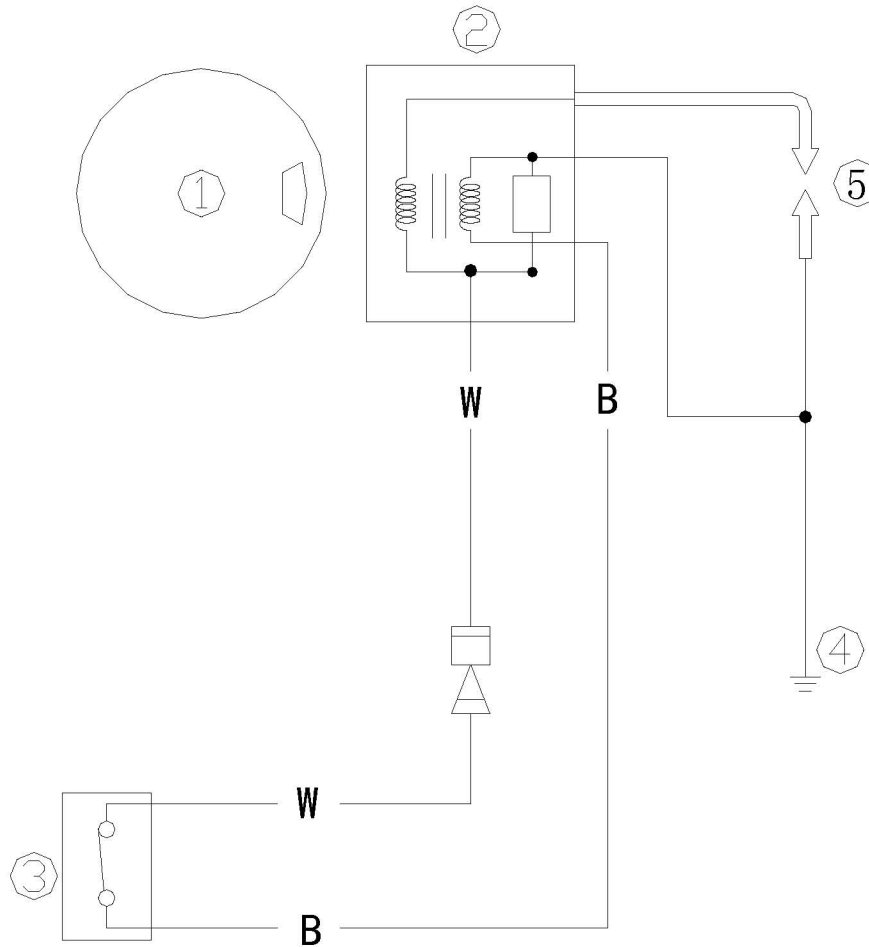

- ① Flywheel
- ② Ignition coil
- ③ Engine stop switch
- ④ Grounding
- ⑤ Spark plug

Wire beam color: W White
B Black

SPARK PLUG IGNITION

1. Remove spark plug cap from spark plug. .
2. Connect the ignition tester to the spark plug cap.
3. Start the engine, and observe the sparks through the discharge window of the tester.

⚠ WARNING

Do not touch any joint part of the lead wire of the tester.

Keep away from inflammable gas or liquid, to prevent accident resulting from spark ignition.

SPARK PLUG CAP

1. Remove the spark plug. Check if the spark plug cap is broken. Replace if necessary.
2. Measure the resistance. If it's out of specification, replace.
Spark plug cap resistance: 4.0~6.0k Ω
3. Install the spark plug cap
Turn it clockwise until it is tight.

FLYWHEEL MAINTENANCE

1. Use flywheel holder to remove the nut and starter pulley; use flywheel puller to remove flywheel.



2. Check if the flywheel is damaged or the permanent magnet part is firm. Replace if necessary.

IGNITION COIL INSPECTION

1. Ignition coil peak voltage
 - ① Remove spark plug cap.
 - ② Disconnect ignition coil tip (W).
 - ③ Measure the ignition coil peak voltage output by a digital universal meter and a peak voltage adapter. If below specification, check the ignition coil.
Peak voltage output: 130V (1500 r/min)



Digital universal meter



Peak voltage adapter

2. Ignition coil resistance
 - ① Remove ignition coil and spark plug cap.
 - ② Measure ignition coil resistance. If out of specification, replace it.
Resistance: 0.7~0.96 Ω (Tester (+) pole: white wire; Tester (-) pole: black wire)
11.6~7.0k Ω (Tester (+) pole: white wire; Tester (-) pole: high-voltage wire)

FUEL SYSTEM

NOTICE

Gasoline is inflammable and highly volatile liquid. Its leakage can cause fire and explosion. Don't start the engine before all joints of the fuel system are connected or installed. When completing all maintenance steps, force short-time pressure to the fuel system to check for leakage.

EXPLOSIVE DRAWING

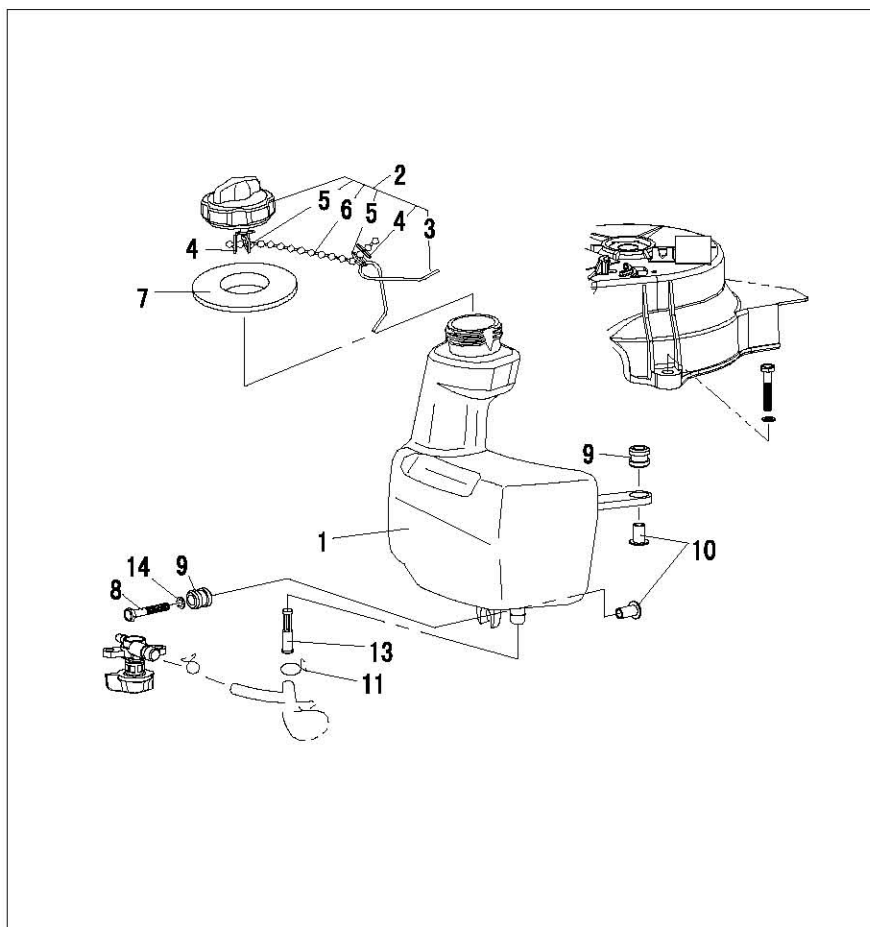

参照号码 SN.	零件编号 PART NO.	零件名称 DESCRIPTION	数量 QTY	备注 REMARKS
1	F4-04120001	油箱 TANK	1	
2	F4-04120100	油箱盖组件 TANK COVER ASSY	1	
3	F4-04120103	防脱落扭簧 SPRING, PREVENT DESQUAMATING	1	
4	F4-04120105	防脱落卡片 SHEET METAL, PREVENT DESQUAMATING	2	
5	F4-04120106	钢丝锁圈 EYBLET, STEEL WIRE	2	
6	F4-04120104	防脱链 CHAIN, PREVENT DESQUAMATING	1	
7	F4-04120111	油箱盖橡胶密封垫 GASKET, TANK COVER	1	
8	GB/T5783-2000	六角头螺栓M6×25 HEXAGON BOLT	1	
9	F4-04120002	油箱减震器 DAMPER, TANK	3	
10	F4-04120003	减震器衬套 BUSH, DAMPER	3	

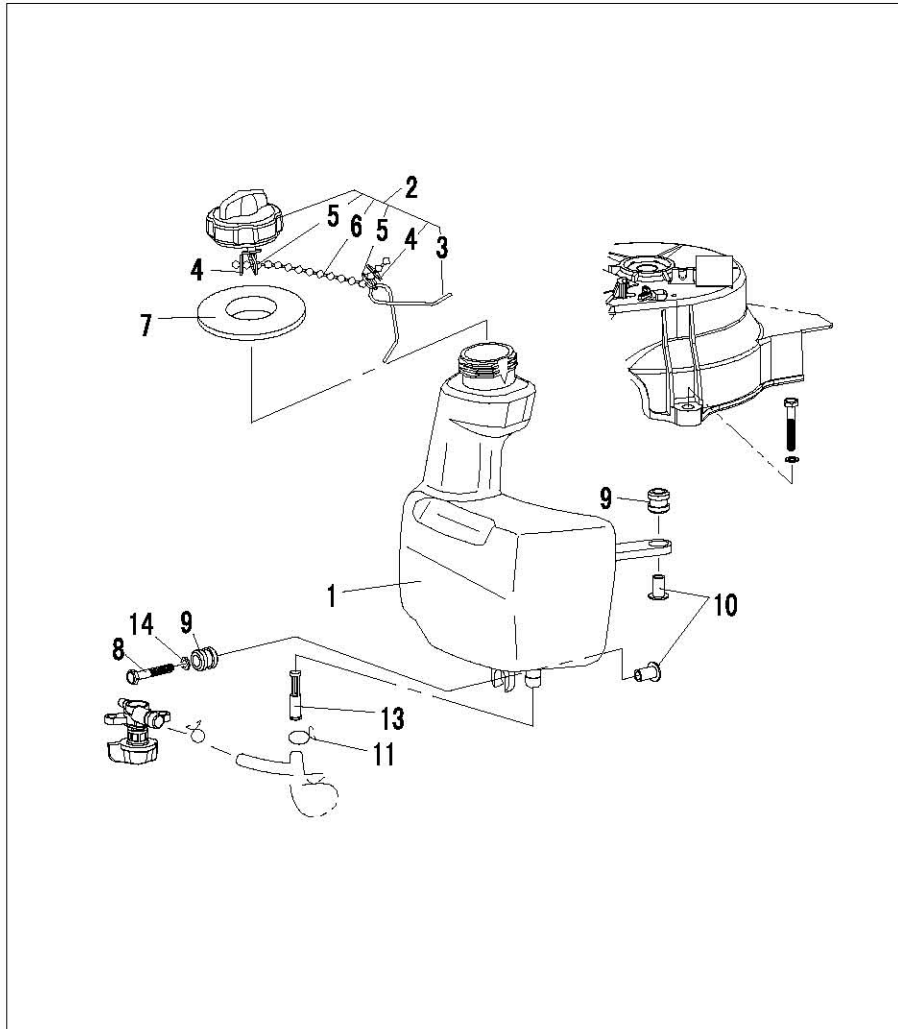

参照号码 SN.	零件编号 PART NO.	零件名称 DESCRIPTION	数量 QTY	备注 REMARKS
11	F4-04000030	油管夹簧B CLIP , OIL PIPE "B"	2	
12	F4-05000005	燃油管A PIPE , FUEL "A"	1	
13	F4-04120005	油箱滤油芯 STRAINER , TANK	1	
14	GB/T97.1-85	平垫圈6 WASHER , PLATE	1	

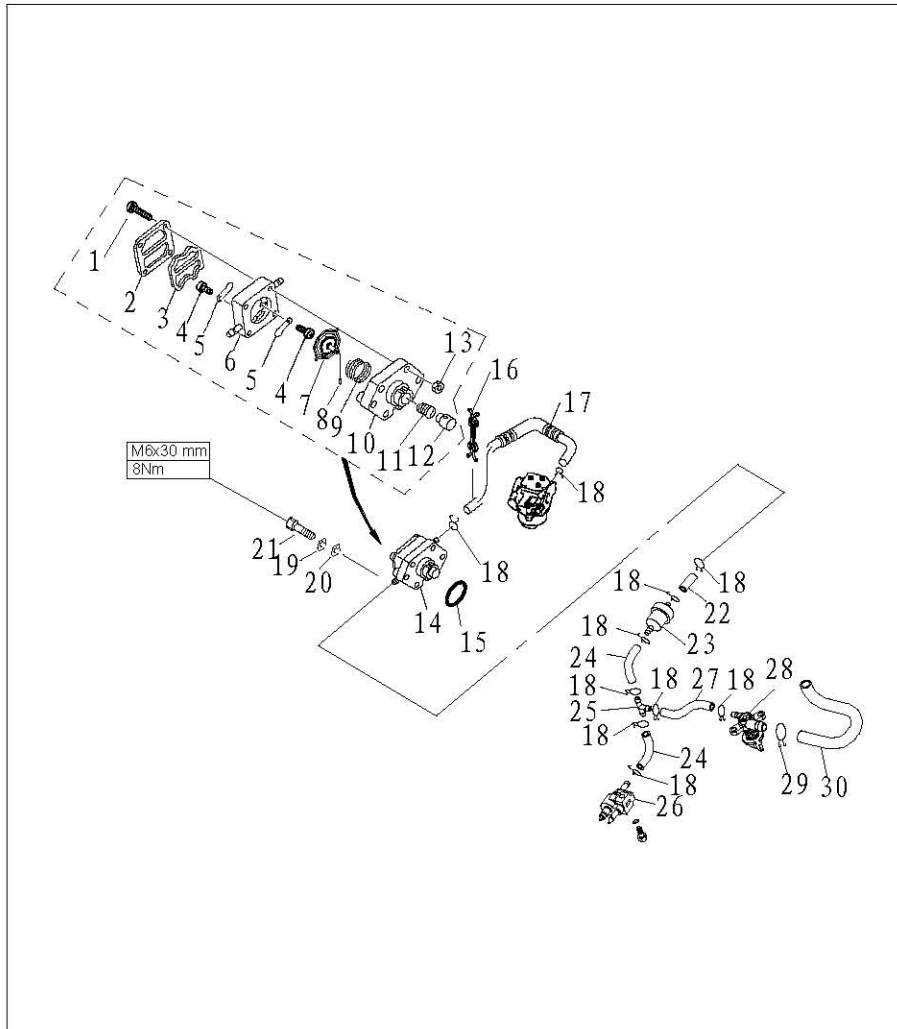

参照号码 SN.	零件编号 PART NO.	零件名称 DESCRIPTION	数量 QTY	备注 REMARKS
1	GB/T823-88	十字槽小盘头螺钉M4×25	4	SCREW , SMALL PAN HEAD
2	F4-04090003	燃油泵盖	1	COVER, FUEL PUMP
3	F4-04090004	上隔膜	1	DIAPHRAGM , TOP
4	F4-04090011	阀片螺钉M3×5	2	SCRRW , VALVE
5	F4-04090005	单向阀片	2	PLATE
6	F4-04090002	燃油泵壳	1	FUEL PUMP SHELL
7	F4-04090100	隔膜组件	1	DIAPHRAGM ASSY
8	GB/T309-2000	滚针 φ 3x12	1	ROLLER NEEDLE
9	F4-04090008	隔膜弹簧	1	SPRING , DIAPHRAGM
10	F4-04090001	燃油泵座	1	SEAT , FUEL PUMP

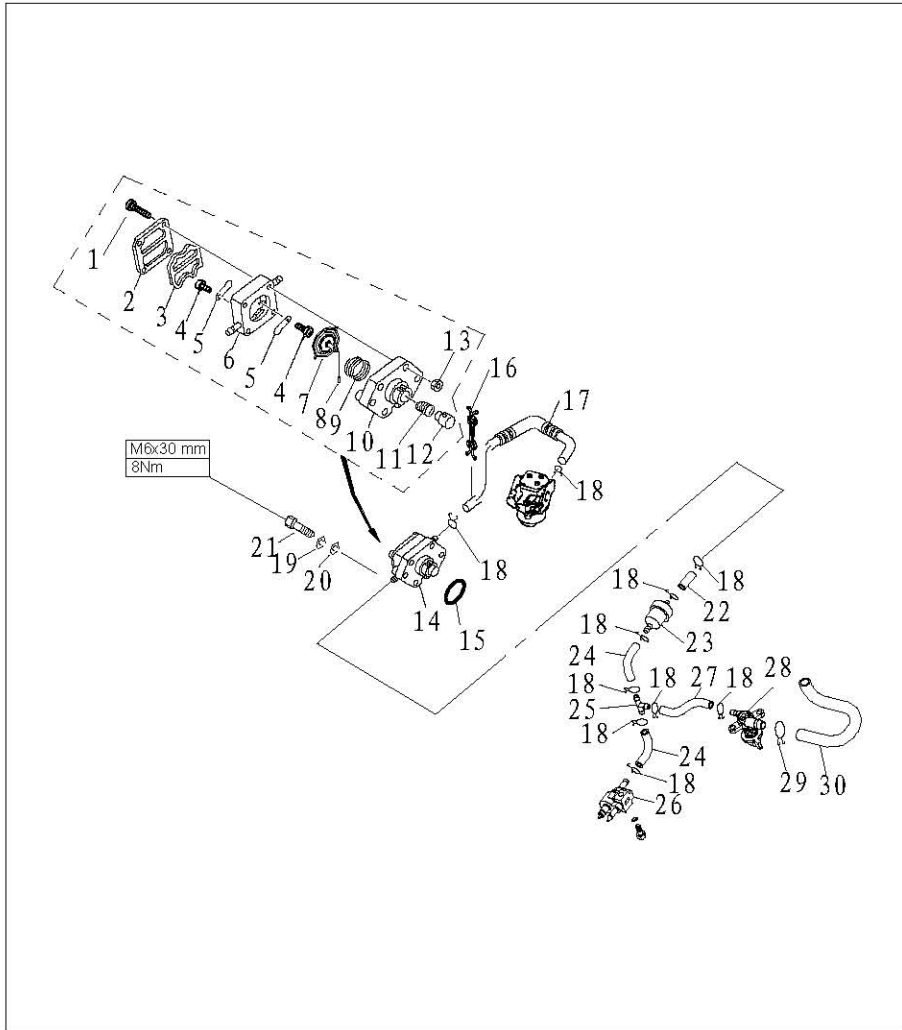

参照号码 SN.	零件编号 PART NO.	零件名称 DESCRIPTION	数量 QTY	备注 REMARKS
11	F4-04090007	柱塞弹簧 SPRING ,PLUNGER	1	
12	F4-04090006	柱塞 PLUNGER	1	
13	GB/T6170-2000	螺母 M4 NUT	4	
14	F4-04090000	燃油泵组件 FUEL PUMP ASSY	1	
15	F4-04090009	燃油泵座O形圈 O-RING	1	
16	F4-0400031-2	尼龙管夹 CLIP ,NYLON "B"	1	
17	F4-04000028	燃油管E PIPE ,FUEL "E"	1	
18	F4-04000030	油管夹簧 SPRING ,FUEL PIPE "B"	9	
19	GB/T93-1987	弹簧垫圈 6 WASHER ,SPRING	2	
20	GB/T97.1-85	平垫圈 6 WASHER ,PLATE	2	

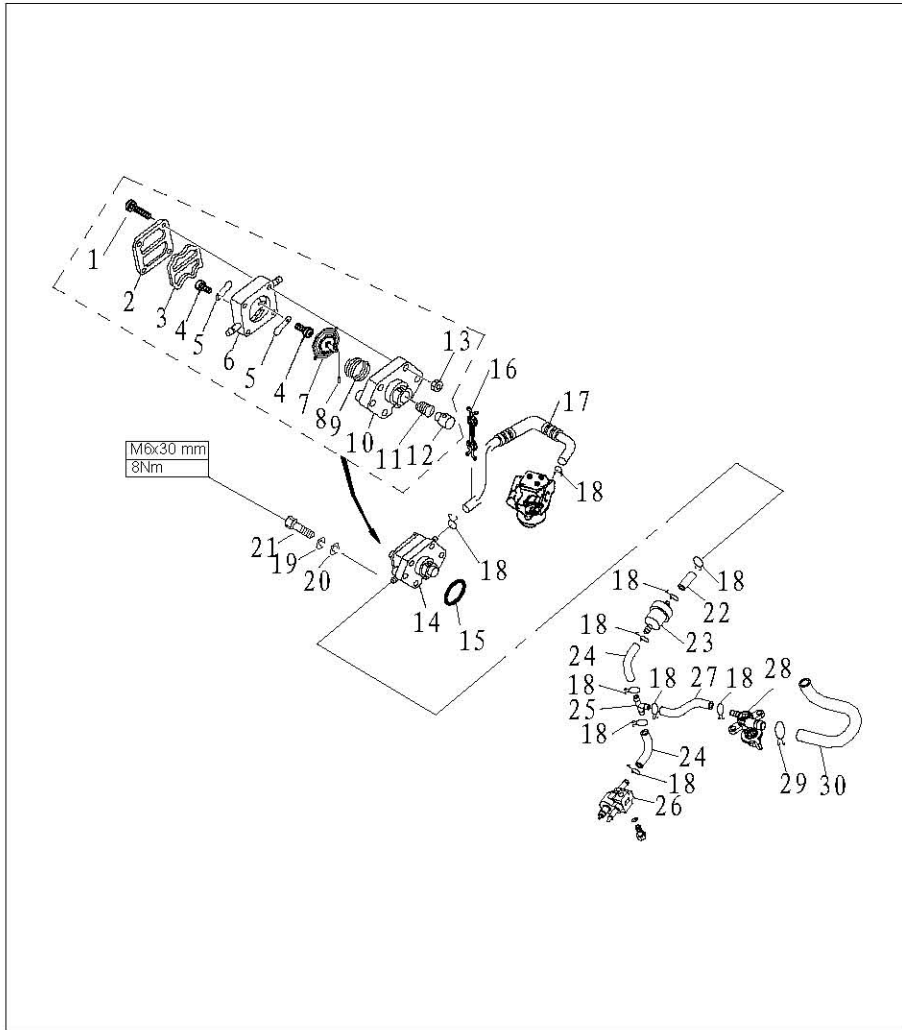

参照号码	零件编号	零件名称	数量	备注
SN.	PART NO.	DESCRIPTION	QTY	REMARKS
21	GB/T5783-2000	六角头螺栓 M6×30 HEXAGON BOLT	2	
22	F4-05000008	燃油管D PIPE ,FUEL "D"	1	
23	F4-05000300	燃油过滤器组件 FUEL FILTER ASSY	1	
24	F4-05000007	燃油管C PIPE ,FUEL "C"	1	
25	F1S-05000011	三通 THREE THROUGH	1	
26	F4-05000300	燃油管接头组件 FUEL PIPE TIE-IN ASSY	1	
27	F4-05000006	燃油管B PIPE ,FUEL "B"	1	
28	F4-05000100	油开关 OIL SWITCH	1	
29	F4-05000010	油管夹簧A SPRING ,OIL TUBE CLAMP	1	
30	F4-05000005	燃油管A PIPE FUEL "A"	1	

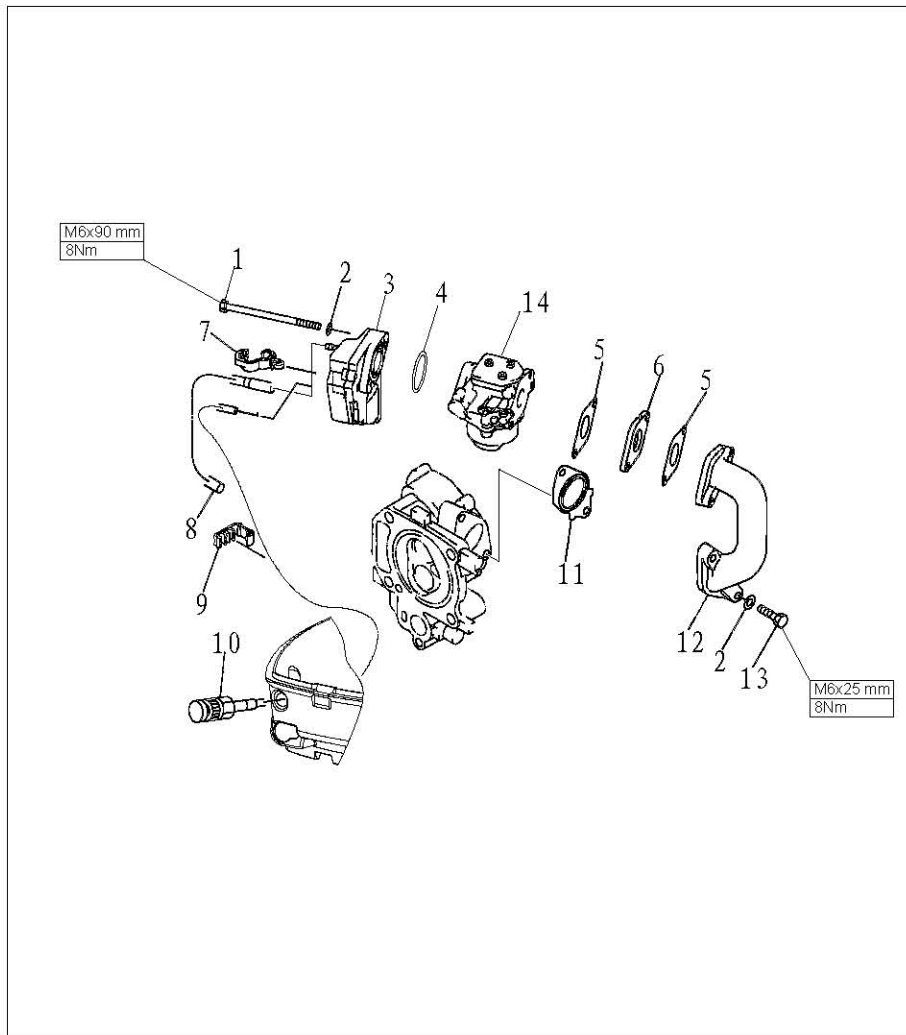

参照号码	零件编号	零件名称	数量	备注
SN.	PART NO.	DESCRIPTION	QTY	REMARKS
1	GB/T5284-86	六角头螺栓M6x90	2	HEXAGON BOLT
2	GB/T97.1-85	平垫圈6	4	WASHER , PLATE
3	F4-04110000	进气消音器组件	1	SILENCER ASSY , INTAKE
4	JASO F404-96	O形密封圈2-24-031	1	O-RING
5	F4-04000024	化油器密封垫	2	GASKET , CARBURETOR AIRPROOF
6	F4-04000025	化油器垫块	1	GASKET , CARBURETOR
7	F4-04110006	齿形尼龙卡箍	1	CLAMP , NYLON DENTIFORM
8	F4-04000035	回气管	1	PIPE , RETURN GAS
9	F4-04000031-1	尼龙管卡 (A)	1	CLAMP , NYLON "A"
10	F4-05000400	阻风门拉柄组件	1	CHOKE HANDLE ASSY

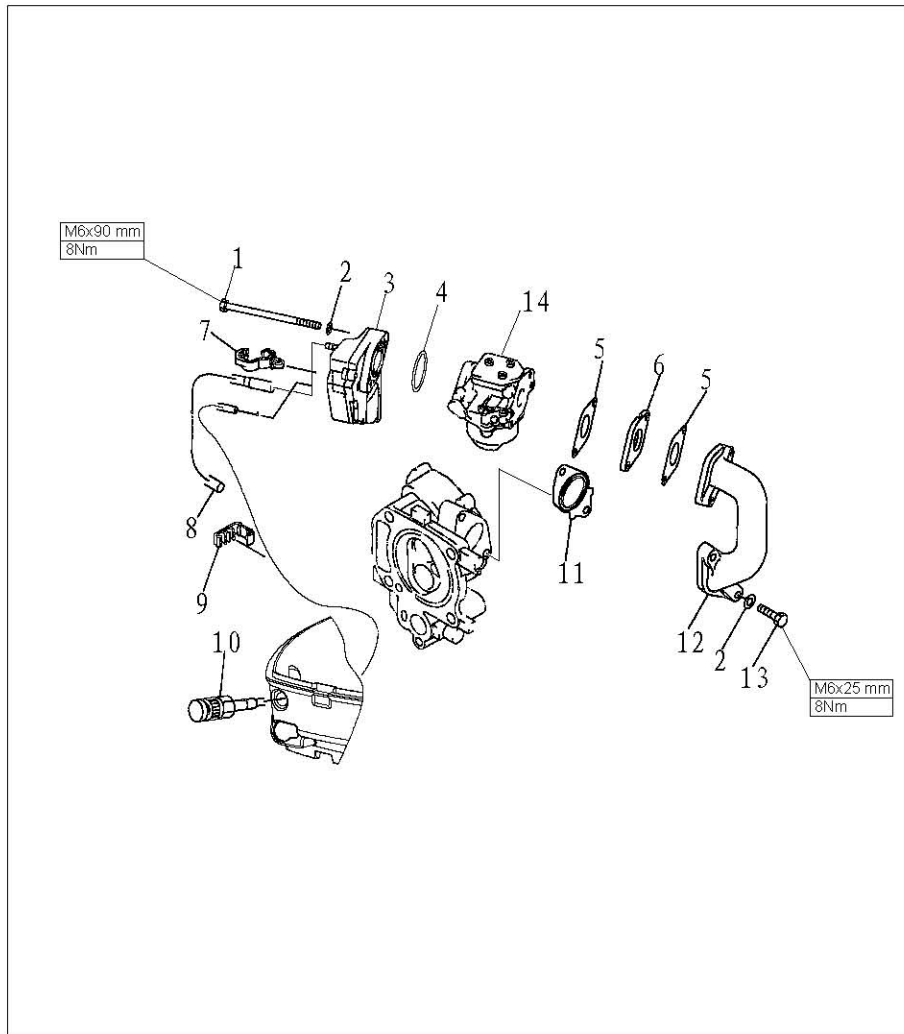

参照号码 SN.	零件编号 PART NO.	零件名称 DESCRIPTION	数量 QTY	备注 REMARKS
11	F4-04000022	进气弯管密封垫 GASKET ,INNER PIPB	1	
12	F4-04000025	进气歧管 MANIFOLD ,INTAKE	1	
13	GB/T97.1-85	六角头螺栓 M6x25 HEXAGON BOLT	2	
14	F4-04000025	化油器 CARBURETOR	1	

FUEL TANK REMOVAL AND INSPECTION

1. Open the top cowling.
2. Remove three bolts fixing the starter.
3. Remove the starter. Pull the fuel tank out.
4. Remove the fuel pipe from fuel tank.

5. Inspect the fuel tank and fuel tank cover for crack, leakage or damage.
Replace if necessary.
6. Inspect the tank strainer for dirt or clog. Clean or replace if necessary.



OIL SWITCH REMOVAL AND INSPECTION

1. Remove the fuel tank.
2. Remove the bolts fixing the thumb wheel of the oil switch, and remove the thumb wheel.

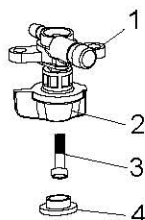

1. Oil switch 2. Thumb wheel 3. Plus pan head screw M4X12 4. Thumb wheel block

3. Remove the bolts fixing the oil switch, and remove oil switch.

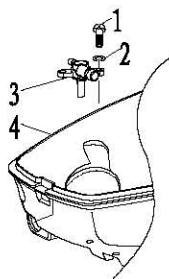

1. Screw 2. Gasket 3. Oil switch 4. Bottom cowling

4. Inspect the oil switch for leakage under prescribed pressure, replace if necessary.
Prescribed air pressure: 0.1Mpa



FUEL JOINT REMOVAL AND INSPECTION

1. Remove the bolts fixing the fuel joint.
2. Remove the fuel joint.

3. Inspect the fuel joint for crack or damage.

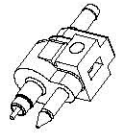

4. Connect the fuel joint exit with a vacuum pressure gauge.
5. Check whether the negative pressure can be maintained for over 10 minutes under the prescribed pressure. Replace if necessary.
Prescribed pressure: 50kPa.

FUEL PUMP REMOVAL AND INSPECTION

1. Remove the bolts fixing the fuel pump.
2. Remove the fuel pump.
3. Connect the fuel pump intake with a vacuum pressure gauge.
4. Block the exit of fuel pump with finger, and force a prescribed positive pressure to check for leakage.
Prescribed pressure: 50kPa
5. Force a prescribed negative pressure and check for leakage.
Prescribed pressure: 50kPa
6. Connect the fuel pump exit with a vacuum pressure gauge.
7. Force a prescribed negative pressure and check for leakage. Disassemble the fuel pump to check if necessary.
Prescribed pressure: 50kPa
8. Remove four bolts, and separate fuel pump cover from fuel pump seat.
9. Remove the valve screw bolt from fuel pump, and remove the valve plate.
10. Press the plunger and diaphragm, rotate the fuel pump seat, and align the notch with the notch on the plunger. Take the roller needle out.
11. Inspect the diaphragm for crack and valve for damage. Replace if necessary.

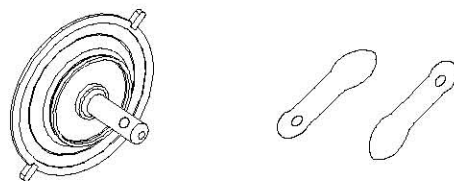

12. Reverse above step 8 to step 10 to install the fuel pump.

INTAKE SYSTEM REMOVAL AND INSPECTION

- 1 . Loose throttle cable stop screw, and remove throttle cable.



1. Throttle cable stop screw

- 2 . Remove choke cable from carburetor. Remove choke cable.

- 3 . Remove the bolt fixing air filter.

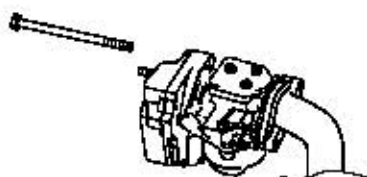

- 4 . Remove air filter and carburetor.

- 5 . Remove intake manifold from engine.

- 6 . Check if air filter and intake manifold are cracked or damaged. Replace it if necessary.

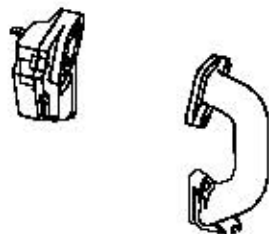

POWER UNIT

NOTICE

To prevent the engine from accidental starting, you should adopt adequate safeguard measures to cut off the ignition system. For example: remove the hang rope stopper from stop switch assembly, and remove spark plug cap from spark plug.

EXPLOSIVE DRAWING

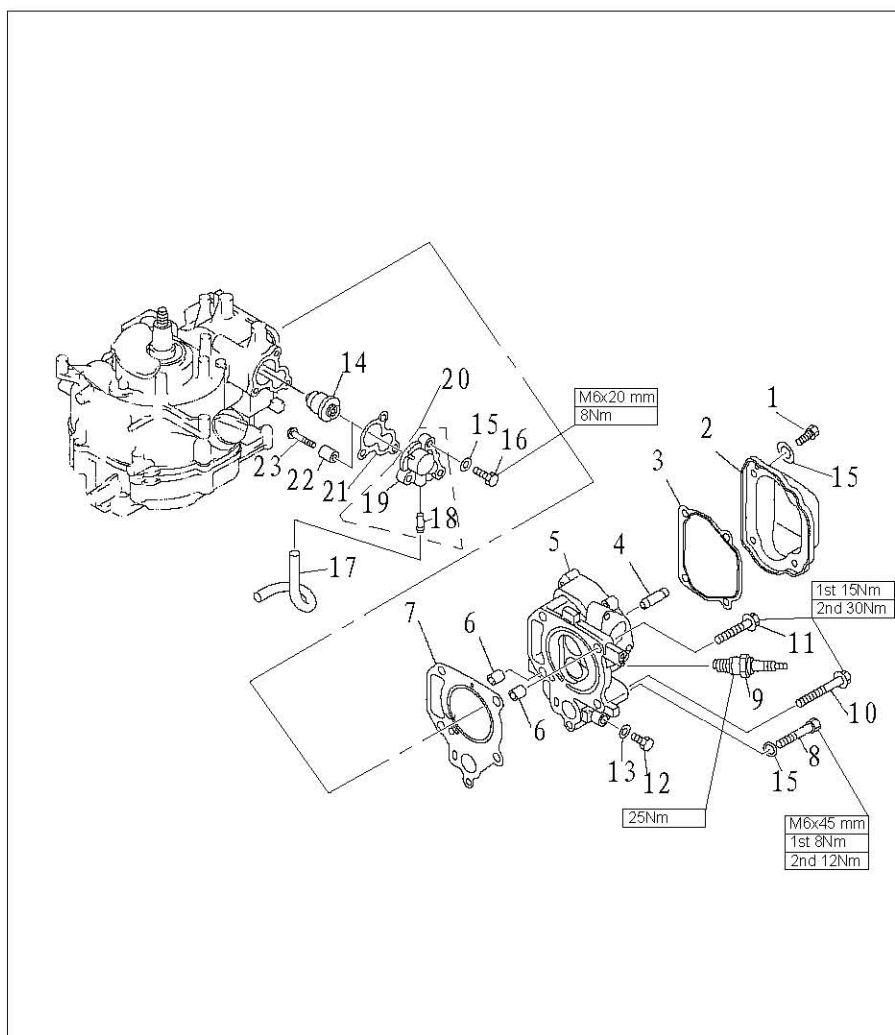

参照号码 SN.	零件编号 PART NO.	零件名称 DESCRIPTION	数量 QTY	备注 REMARKS
1	GB/T5783-86	六角头螺栓M6×16 HEXAGON , BOLT	4	
2	F4-04000018	缸头罩 COVER , CYLINDER HEAD	1	
3	F4-04000017	缸头罩密封垫 GASKET , CYLINDER COVER	1	
4	F4-04080002	气门导管 PIPE , VALVE	2	
5	F4-04080101	气缸头 CYLINDER , HEAD	1	
6	F4-04000003	空心定位销 PIN , HOLLOW	2	
7	F4-04000014	缸头复合垫 GASKET , CYLINDER HEAD	1	
8	GB/T5782-1986	六角螺栓M6×45 HEXAGON , BOLT	1	
9	BPR7HS	火花塞 PLUG , SPARK	1	
10	F4-04000033	气缸头螺栓A BOLT , CYLINDER HEAD "A"	3	

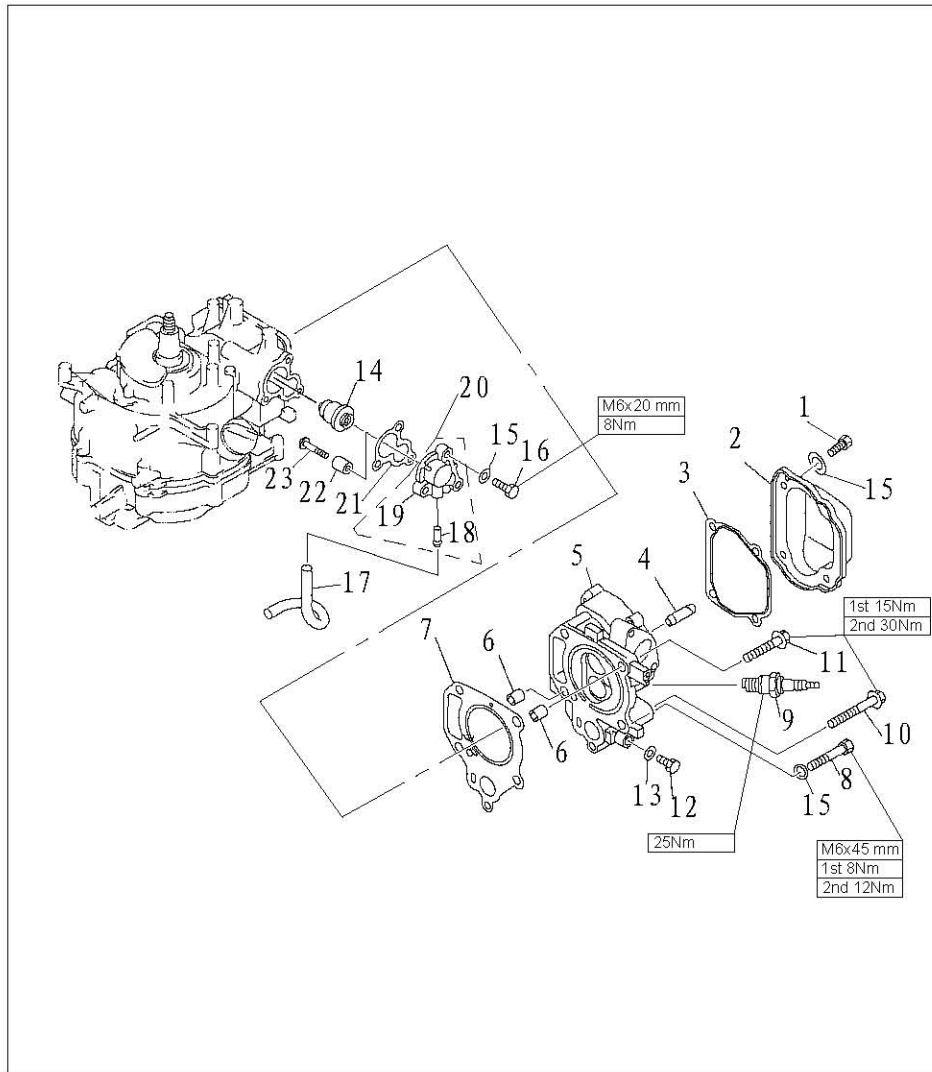

参照号码 SN.	零件编号 PART NO.	零件名称 DESCRIPTION	数量 QTY	备注 REMARKS
11	F4-04000034	气缸头螺栓B BOLT	1	
12	GB/T5783-2000	六角头螺栓M8×14 BOLT, HEXAGON	1	
13	GB/T97.1-85	平垫圈8 WASHER, PLATE	1	
14	F4-04000036	节温器 THERMOSTAT	1	
15	GB/T97.1-85	平垫圈6 WASHER, PLATE	8	
16	GB/T5783-2000	六角头螺栓M6×20 BOLT, HEXAGON	3	
17	F4-04000012	回水管 PIPE, RETURN	1	
18	F4-04010002	水咀 SPILE WATER	1	
19	F4-04070001	节温器盖 COVER, THERMOSTAT	1	
20	F4-04070100	节温器盖水咀组件 COVER AND SPILE WATER ASSY	1	

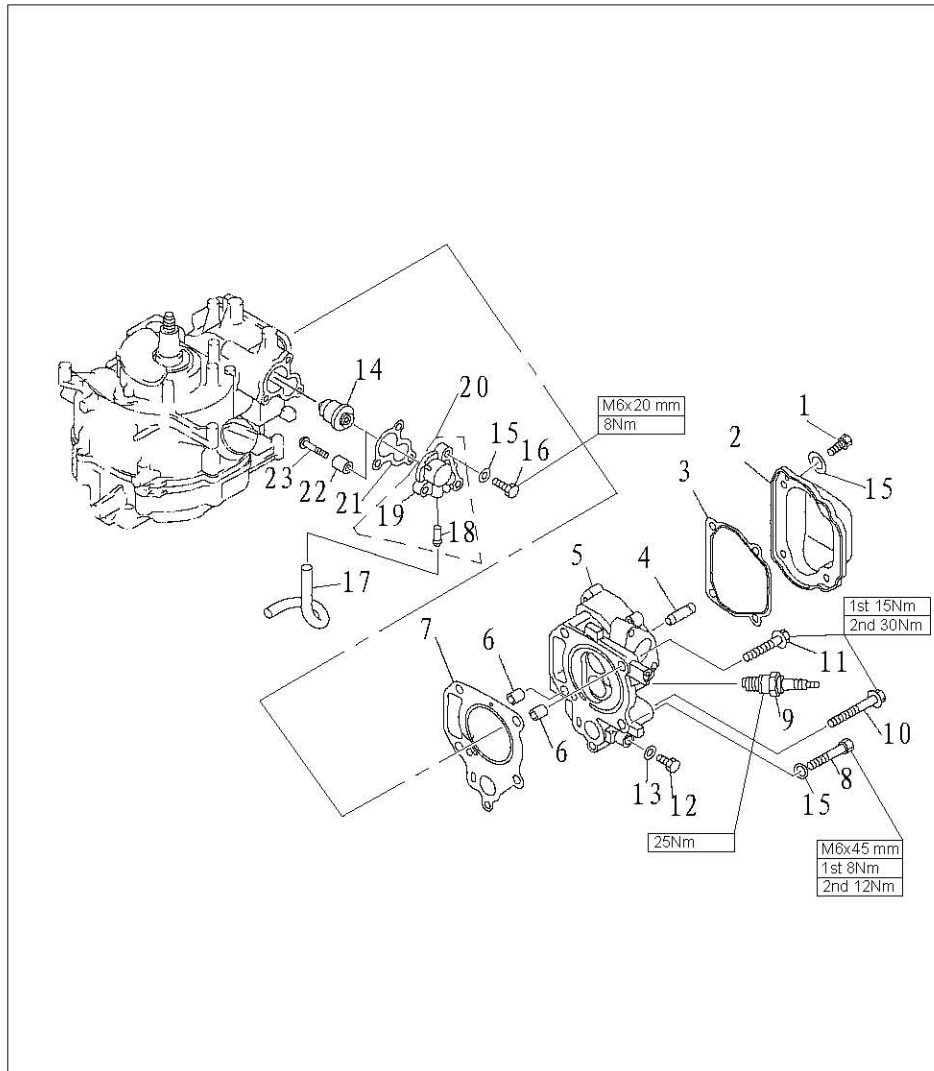

参照号码 SN.	零件编号 PART NO.	零件名称 DESCRIPTION	数量 QTY	备注 REMARKS
21	F4-04000011	节温器盖密封垫 GASKET ,THERMOSTAT	1	
22	F4-04070003	节温器盖阳极 ANODE	1	
23	GB/T818-85	十字槽盘头螺钉M5×25 SCREW , PAN HEAD	1	

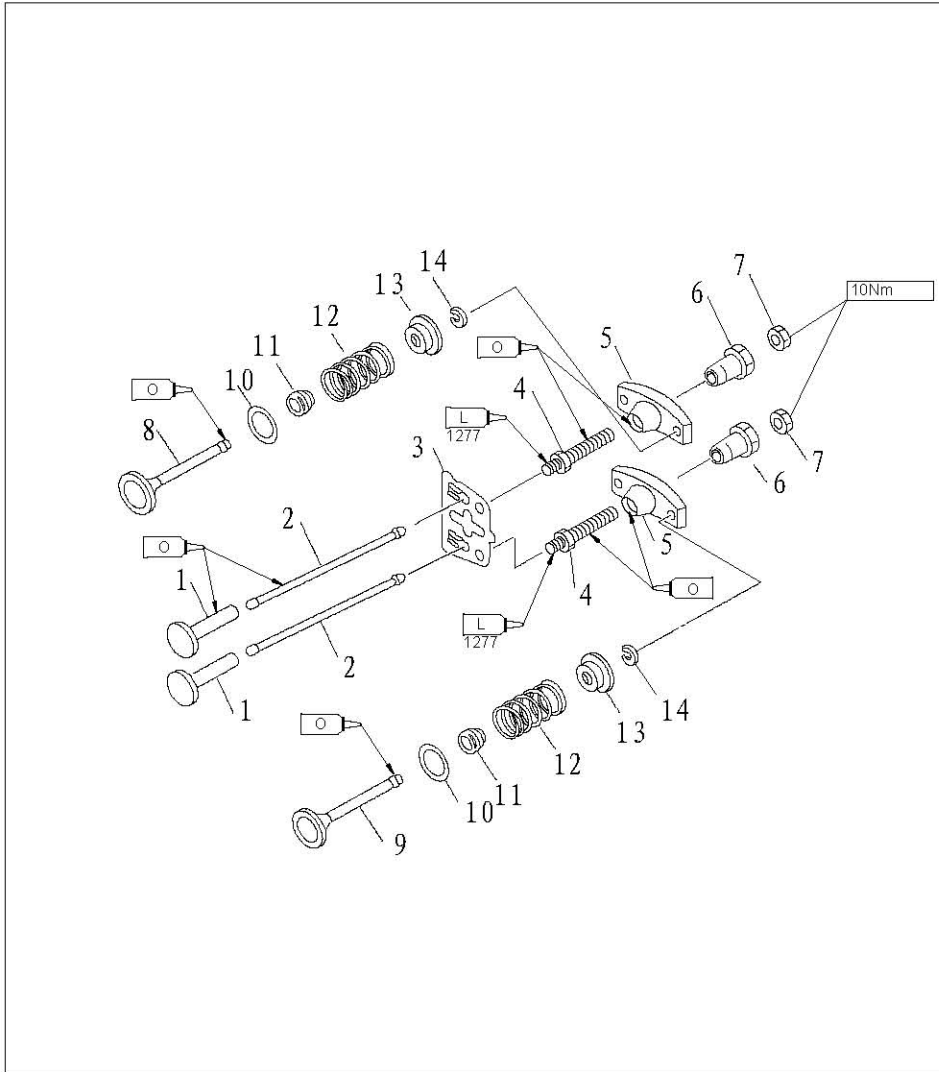

参照号码 SN.	零件编号 PART NO.	零件名称 DESCRIPTION	数量 QTY	备注 REMARKS
1	PS2700. 03. 02	气门挺柱 LIFTER, VALVE	2	
2	F4-04000015	气门推杆 ROD, VALVE PUSH	1	
3	F4-04080009	导向板 PLATE, PUSH ROD	1	
4	PS2700. 04. 12	摇臂螺栓 BOLT, ROCKER ARM	2	
5	PS2700. 04. 12	气门摇臂 ARM, VALVE ROCKER	2	
6	PS2700. 04. 13	摇臂球座 PIVOT, ROCKER ARM	2	
7	PS2700. 04. 18	六角螺母M6x0. 75 BOLT	1	
8	F4-04080005	进气门 DOOR, INTAKE	1	
9	F4-04080006	排气门 DOOR, EXHAUST	1	
10	F4-04080007	气门弹簧垫圈 SEAT, VALVE SPRING	2	

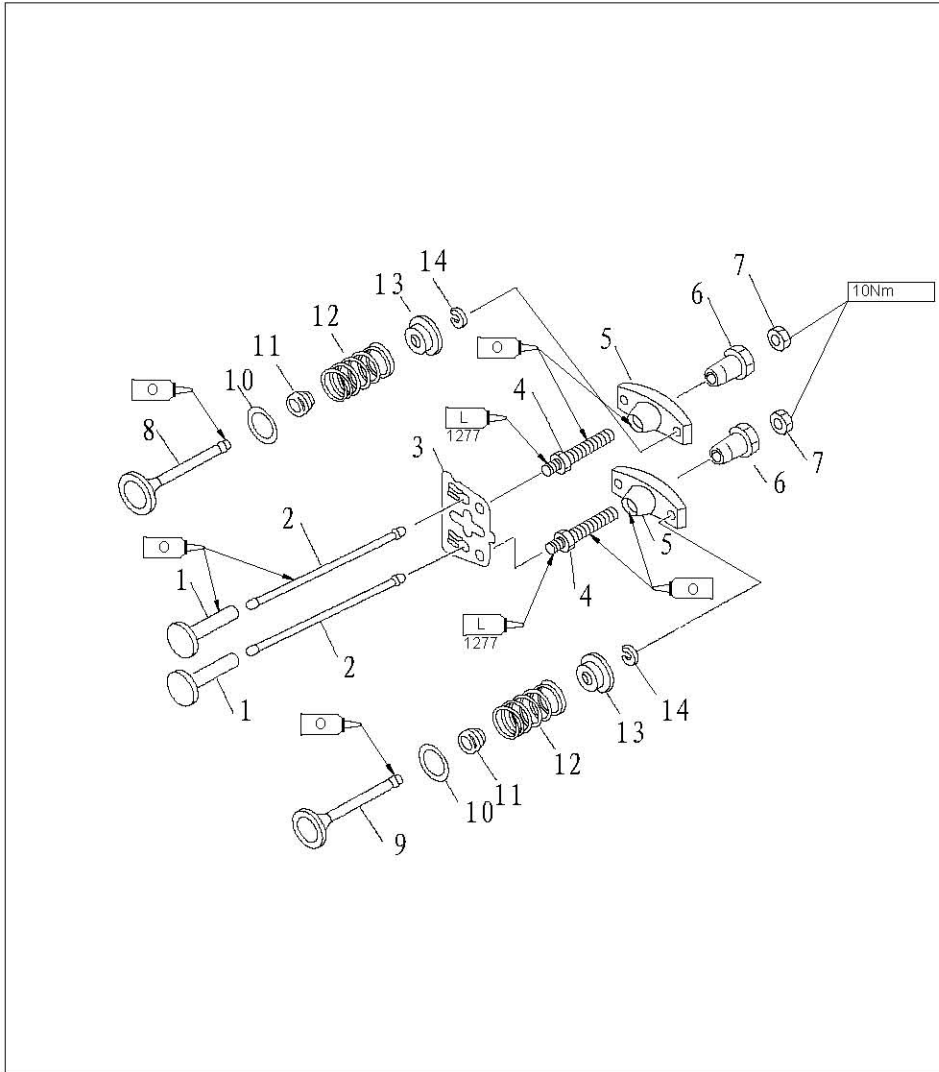

参照号码 SN.	零件编号 PART NO.	零件名称 DESCRIPTION	数量 QTY	备注 REMARKS
11	PS2700.04.03	气门油封 SEAT, VALVE STEM	2	
12	F4-04080008	气门弹簧 SPRING, VALVE INNER	2	
13	F4-04080010	气门弹簧座 SPRING, VALVE RETAINER	2	
14	F4-04080011	气门锁片 CLAMP, VALVE	2	

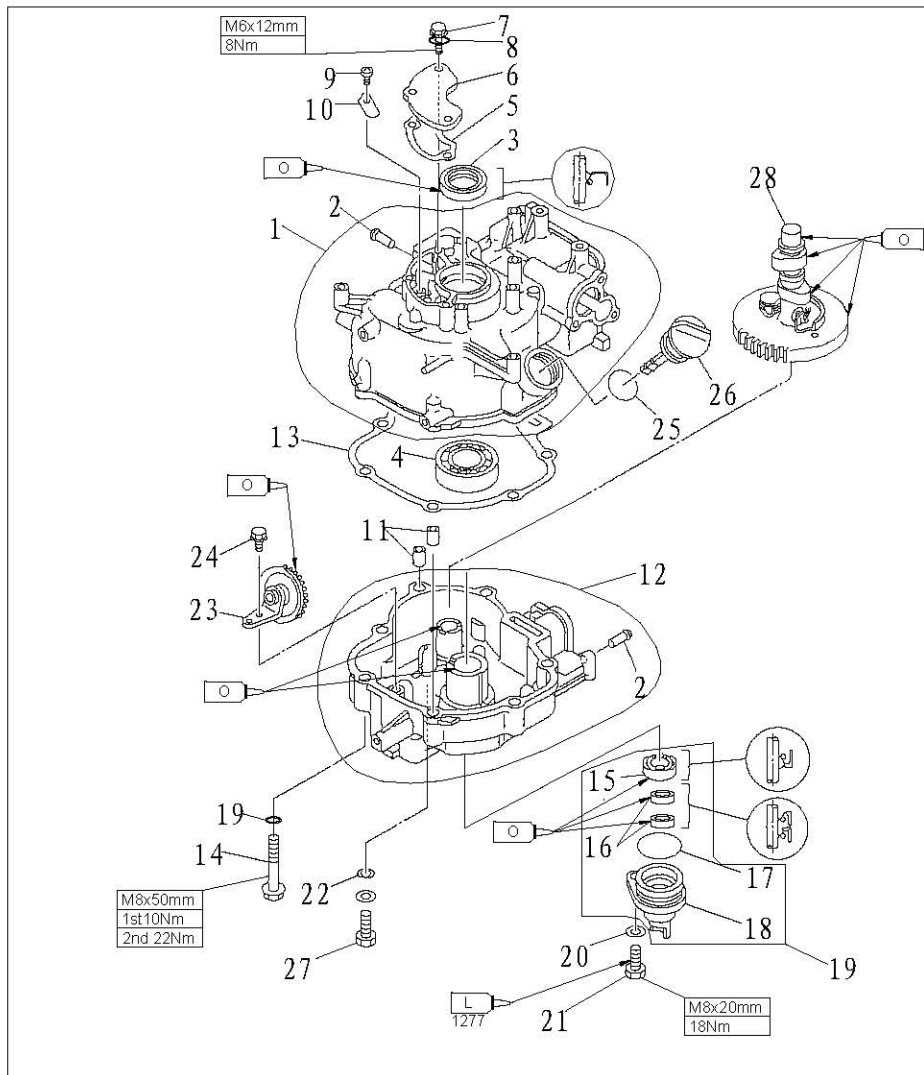

参照号码	零件编号	零件名称	数量	备注
SN.	PART NO.	DESCRIPTION	QTY	REMARKS
1	F4-04010100	曲轴箱体 CRANK CASE	1	
2	F4-04010002	气嘴 PIPE, JOINT	1	
3	F4-04010003	曲轴油封A25x40x5 OIL SEAL	1	
4	GB/T276-94	深沟球轴承6205C3 BEARING	1	
5	F4-04000009	呼吸器密封垫 BREATHER GASKET	1	
6	F4-04000010	呼吸器盖板 COVER	1	
7	GB/T5782-2000	六角头螺栓M6x14 HEXAGON, BOLT	3	
8	GB/T97.1-85	平垫圈6 WASHER	3	
9	GB/T818-85	十字槽盘头螺钉M4x6 SCREW, PAN HEAD	1	
10	F4-04010003	呼吸器阀片 VALVE, BREATHER FLAP	1	

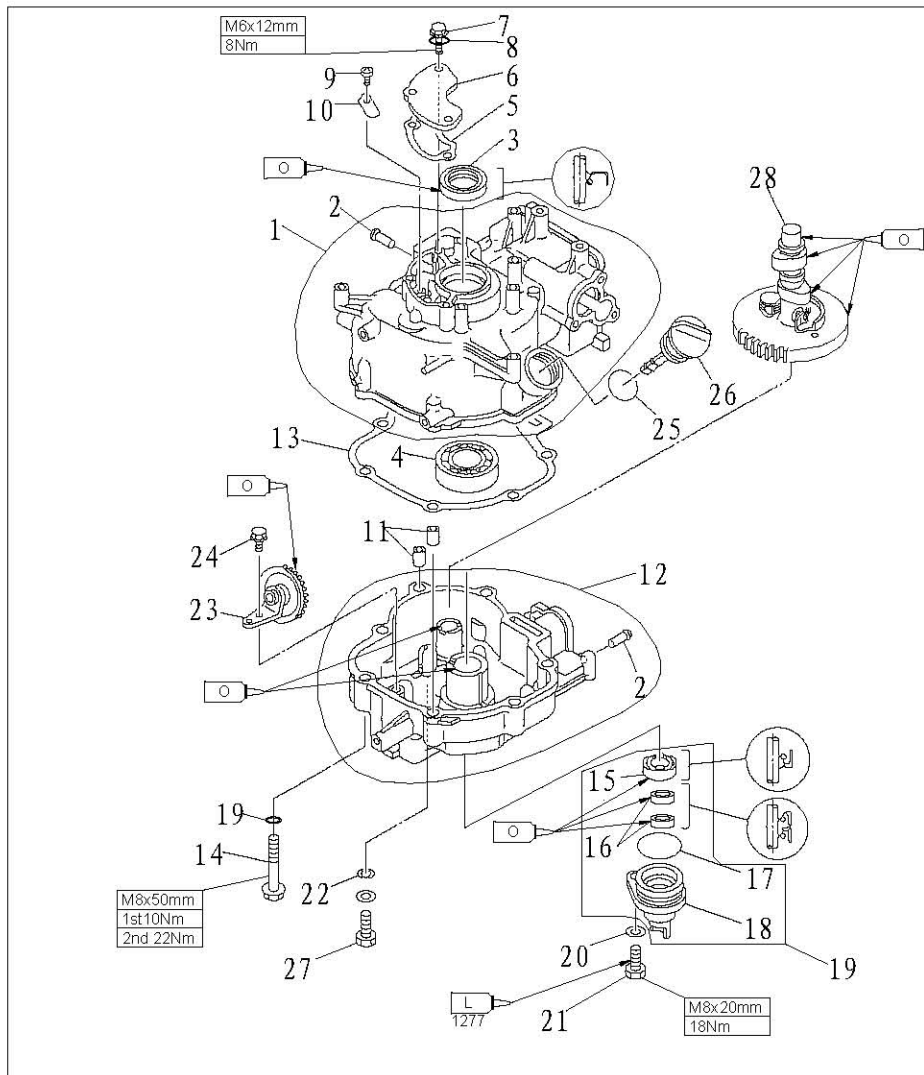

参照号	零件编号	零件名称	数量	备注	
SN.	PART NO.	DESCRIPTION	QTY	REMARKS	
11	F4-04000003	空心定位销 $\phi 10 \times 8.4 \times 14$	HOLLOW PIN	2	
12	F4-04050001	曲轴箱盖	COVER, CRANK CASE	1	
13	F4-04000002	曲轴箱体复合垫	CRANK CASE COMPLEX GASKET	1	
14	GB/T5787-1986	六角法兰面螺栓 M8x50	BOLT, HEXAGON	7	
15	F4-04060003	曲轴油封 20x30x7 (B)	OIL, SEAL	1	
16	F4-04060004	驱动轴上油封 10.8x21x7	OIL, SEAL	2	
17	F4-04060002	油封壳体 O型圈	O-RING	1	
18	F4-04060001	油封壳体	SHELL, OIL SEAL	1	
19	F4-04060000	油封壳体组件	OIL SEAL SHELL ASSY	1	
20	GB/T97.1-85	平垫圈 8	WASHER, PLATE	8	

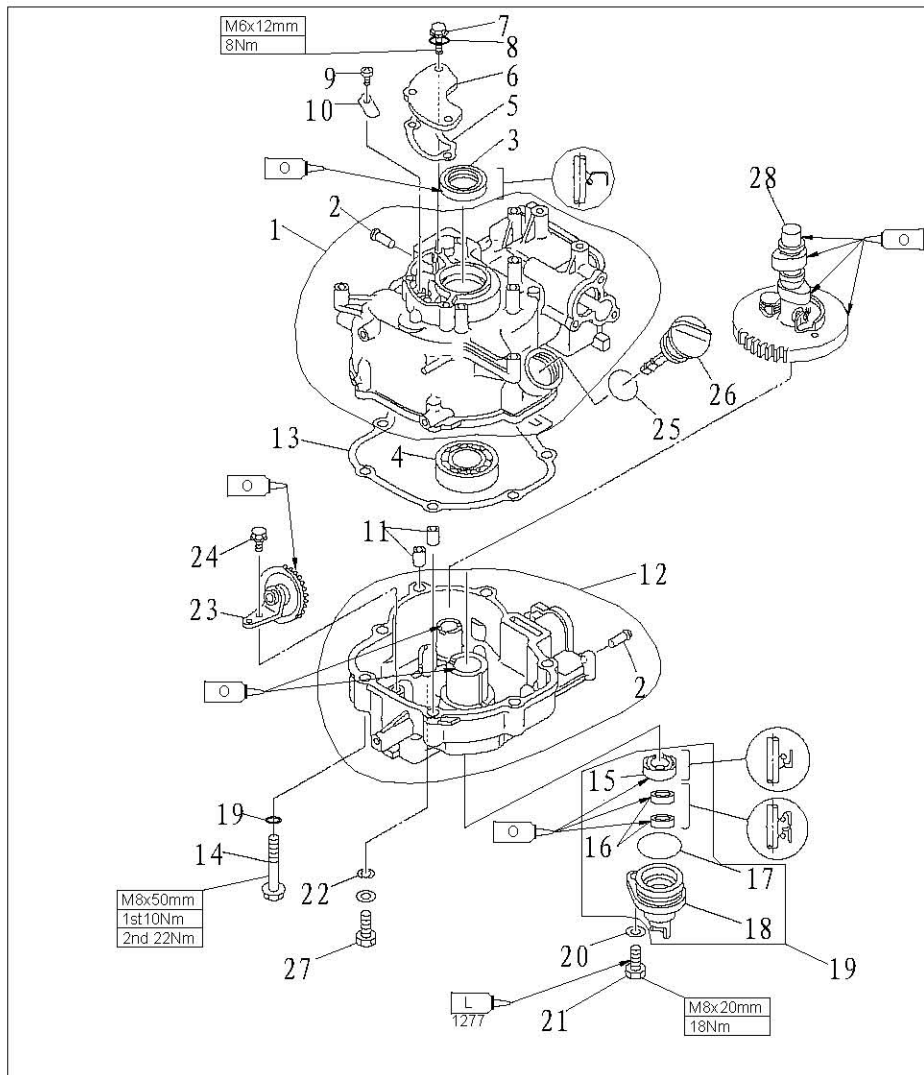

参照号	零件编号	零件名称	数量	备注
SN.	PART NO.	DESCRIPTION	QTY	REMARKS
21	GB/T5783-2000	六角头螺栓M8x20 HEXAGON , BOLT	1	
22	F4-04000006	放油螺栓密封垫 WASHER	1	
23	F4-04050000	甩油轮组件 GEAR UNIT ASSY	1	
24	GB/T5783-2000	六角头螺栓M6x12 BOLT, HEXAGON	1	
25	F4-04000008	机油盖阻油圈 O-RING	1	
26	F4-04000007	带尺机油盖 PLUG WITH DIPSTICK	1	
27	F4-04000001	放油螺栓 BOLT, DISCHARGING OIL	1	
28	F4-04040000	凸轮减压组件 CAMSHAFT ASSY	1	

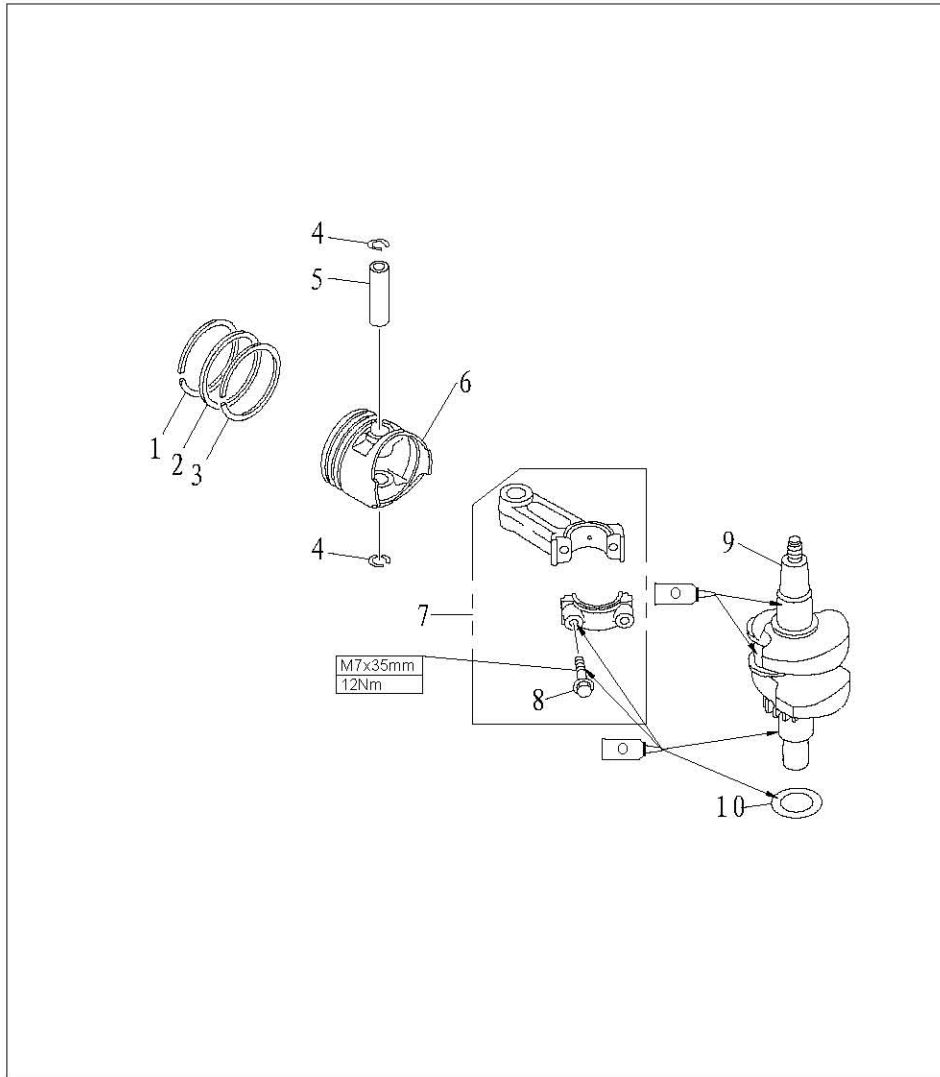

参照号码 SN.	零件编号 PART NO.	零件名称 DESCRIPTION	数量 QTY	备注 REMARKS
1	F4-04020002	气环1 PISTON RING 1	1	
2	F4-04020003	气环2 PISTON RING 2	1	
3	F4-04020004	组合油环 COMBINED OIL RING	1	
4	F4-04020006	活塞销卡簧 CIRCLIP	2	
5	F4-04020005	活塞销 PIN ,PISTON	1	
6	F4-04020001	活塞 PISTON	1	
7	F4-04020100	连杆组件 ROD ,CONNECTING	1	
8	F4-04020103	连杆螺栓 BOLT, ROD CLEVEL	2	
9	F4-04030000	曲轴组件 CRANK ASSY	1	
10	F4-04000004	箱盖减磨片 WASHER , PLATE	1	

SPECIAL TOOLS



Piston slider

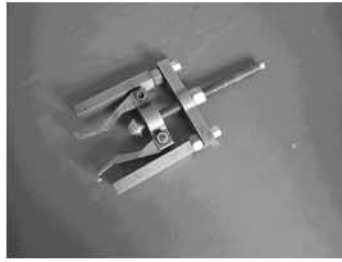

Bearing puller



Valve spring compressor



Housing bearing installer

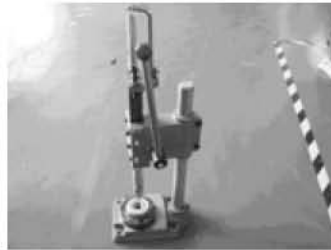

Oil seal installer tool



Housing oil seal installer

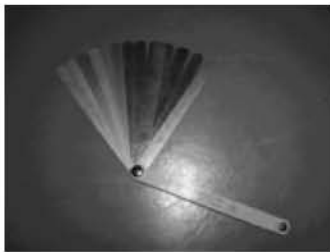

Space gauge

DISASSEMBLING POWER UNIT FROM OUTBOARD ENGINE

1. Open the top cowling.
2. Remove the starter and fuel pump.
3. Remove choke cable and throttle cable.
4. Remove air filter and carburetor.
5. Remove bolts connecting the engine and upper casing.
6. Carry the power unit and put it onto the working table.

DISASSEMBLING AND INSPECTION

CYLINDER COVER

Disassembling

1. Remove the bolts of cylinder head cover.
2. Remove the bolts of the cylinder cover according to the reverse numbering sequence of the cylinder cover.
3. Remove the crankcase cover. Remove the valve push rod.
4. Remove the rocker arm pivot, rocker arm, rocker arm shaft and push rod plate.
5. Use the valve spring compressor to remove intake door and exhaust door.



Push rod

Inspect valve push rod runout. Replace if exceeding the specified value.

Valve push rod runout limit: 0.5mm

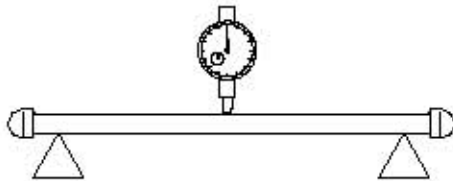

Valve and valve pipe

1. Inspect the valve seat width. If not in the prescribed range, repair the valve seat.
Valve seat width: 0.6~0.8mm
2. Inspect the valve margin thickness (T). If not as in the prescribed value, replace the valve.

The margin thickness of valve:

Intake door: 0.7mm

Exhaust door: 1.00mm

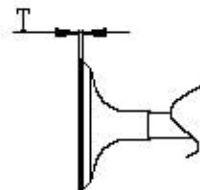

3. Inspect the valve stem diameter. If not in the prescribed range, replace the valve.

The diameter of valve stem:

Intake valve: 5.475~5.490mm

Exhaust valve: 5.460~5.475mm

4. Measure the valve stem runout. If exceeding the limit, replace the valve.
Valve stem runout limit: 0.03mm

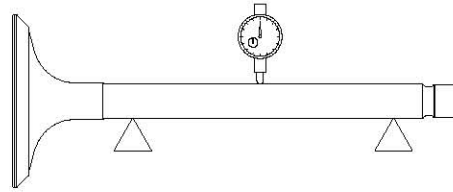

5. Measure the inner diameter of the valve pipe.
The inner diameter of the valve pipe: 5.500~5.512mm

CAUTION:

When replacing the valve, please use the new valve pipe and valve oil seal.

Valve spring

1. Measure the free length of valve spring. If less than prescribed value, replace.
The minimum free length: 34mm
2. Measure the valve spring tilt. If exceeding the prescribed limit, replace.
The maximum tilt limit: 1.2mm

Valve rocker arm

Check the rocker arm for crack, perforation or damage. Replace if necessary.

Valve pipe replacement

1. Knock out the valve pipe from the direction of combustion room.
2. Knock in the new valve pipe from the direction of the top of cylinder cover.

NOTE:

Coat the oil on the surface of pipe before installation.

3. Bore the inner diameter of pipe to the prescribed value by reamer.
Inner diameter of valve pipe: 5.500~5.512mm

NOTE:

When taking out the reamer, don't rotate it in counter clockwise direction.

Valve seat inspection

1. Clean the carbon on the valve.
2. Coat a thin layer of bluing dye evenly onto the seal face of the valve seat.
3. Lap the valve on valve seat by valve lapping tool.
4. Measure the valve seat width.
The valve face is with bluing dye.
If the valve and valve seat do not match, or the valve seat width does not conform to specified value, reface and lap the valve seat.
If the contact surface is not even, replace the valve pipe.

The valve seat width: 0.6~0.8mm

The maximum valve seat width: 1.1mm

Valve seat cutting

1. Use 45° cutter to adjust the valve seat width. Turn the cutter clockwise until the valve seat face is smooth.
2. If the valve seat is centered on the valve face but it's too wide, to reduce the valve seat width, use 30° cutter to adjust the top edge of the seat, and use 60° cutter to adjust the bottom edge of the seat.

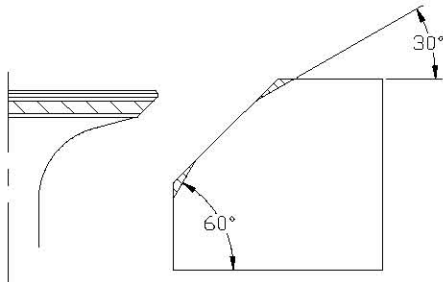

3. If the valve seat is too narrow and on the top edge of valve surface, use 30° cutter to adjust the top margin of the seat, and use 45° cutter to adjust the valve seat width if necessary.

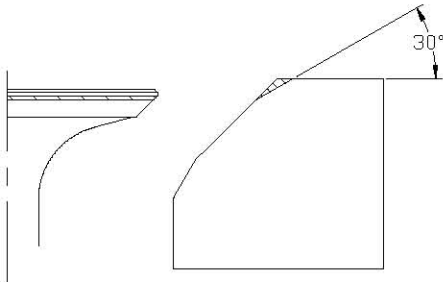

4. If the valve seat surface is too narrow and on the bottom edge of valve surface, use 60° cutter to adjust the bottom edge of the seat, and use 45° cutter to adjust the valve seat width if necessary.

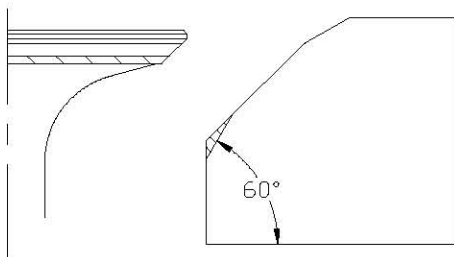

5. Coat evenly a thin layer of lapping compound onto valve seat, and lap the valve by lapping tool.
6. Clean up the remaining lapping compound.
7. Inspect again the valve seat width.

CAUTION:

Do not overlap the valve. Turn the lapping tool evenly with a downward force of 40~50N. Do not contaminate push rod and valve pipe with lapping compound.

Thermostat

1. Remove thermostat cover and thermostat.
2. Suspend thermostat in the container with water.
3. Heat the container.
4. Inspect valve lift situation in the prescribed water temperature. If out of specification, replace.

Water temperature	The lift height
58~62℃	0.05mm valve lift
Over 70℃	Over 3mm

5. Install thermostat and thermostat cover. Tighten the bolts to specified torque.

CRANKCASE

Disassembling

1. Remove the bolts according to the reverse numbering sequence of the crankcase cover .
2. Remove the cover of crankcase.
3. Remove the camshaft and valve lifter.
4. Remove the connecting rod bolt and connecting rod cap, and remove connecting rod and piston assembly.
5. Use clipper to remove circlip, and remove piston pin and piston.
6. Remove crankcase and crankcase gasket.
7. Remove oil splasher gear assembly.
8. Remove breather cover bolts, and remove breather cover.
9. Remove valve bolts and remove valve.
10. Remove oil seal shell bolts, and remove oil seal shell and oil seal.

Breather

1. Inspect breather flap valve, if damaged/cranked/cracked, replace.
2. Inspect breather hole. If clogged, clean.

3. Inspect breather return pipe. If cracked/leaked/damaged, replace.

Piston

Measure piston outside diameter at the specified measuring point. If out of specification, replace.

Piston diameter: 58.950~58.965mm

Measuring point①: 10mm

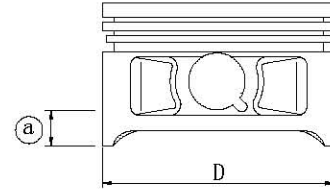

Cylinder bore

1. Measure cylinder bore separately at measuring point ①, ②, ③. At each point, measure the cylinder bore at places D1, D3, D5 parallel to the crankcase and at places D2, D4, D6 vertical to the crankshaft.

Measuring point height:

① 100mm;

② 40mm;

③ 70mm

Cylinder bore: 59~59.02mm

Limit size: 59.10mm

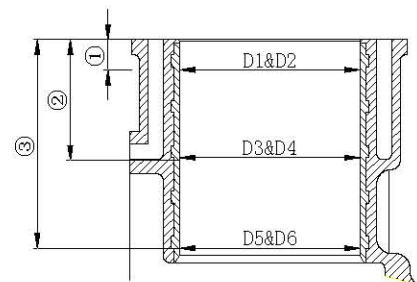

2. Calculate taper limit and round limit. If out of specification, replace crankcase.

Taper limit: 0.08mm(D1-D5, D2-D6)

Round limit: 0.05mm(D2-D1, D6-D5)

Piston pin diameter

Measure piston pin outside diameter. If out of specification, replace the piston pin.

Piston pin outside diameter: 12.995~13.000mm

Piston ring

1. Push the piston ring parallel with the piston crown into the specified measuring point of the cylinder (10mm from conjunction surface).

2. Measure end gap by space gauge. If out of specification, replace the piston ring.

End gap (installed) / limit size: Top ring 0.10~0.20mm/0.4mm

2nd ring 0.25~0.40mm/0.6mm

Oil ring 0.2~0.7mm/0.9mm

3. Install piston ring to piston, and measure side clearance between piston ring and its slot by clearance gauge. If out of specification, replace the piston ring.

Side clearance: Top ring 0.04~0.08mm

2nd ring 0.02~0.06mm

Camshaft decompressor

1. Inspect camshaft decompressor, gear, and weight. If gear is worn/damaged/cracked, replace.

If weight is unsmoothly moving, replace.

2. Measure camshaft lobe diameter[Ⓐ] and height [Ⓑ]. If out of specification, replace it.

Ⓐ Intake camshaft: 21.950~22.050mm

Exhaust camshaft: 21.950~22.050mm

Ⓑ Intake camshaft: 26.736~26.836mm

Exhaust camshaft: 26.532~26.623mm

3. Measure camshaft diameter. If out of specification, replace the camshaft.

Camshaft journal wear limit: 14.934mm

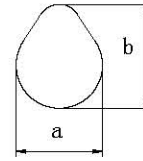

Crankshaft

Measure crankshaft runout. If out of specification, replace.

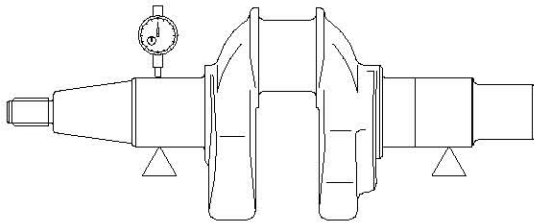

Crankshaft runout limit: 0.03mm

Oil clearance

1. Put a piece of plastic space gauge on to the crankpin in parallel to the crankshaft.
2. Assemble the connecting rod to the crankpin.
3. Tighten the connecting rod bolts to the specified torque.
Tightening torque: 12Nm
4. Remove the connecting rod, measure the compressed width of the plastic space gauge. If out of specification, replace the connecting rod.

Oil clearance: 0.020~0.052mm

Note:

Don't rotate the connecting rod before completing measurement.

Valve lifter

1. Inspect valve lifter for wear or damage. Replace if necessary.
2. Measure valve lifter outside diameter. If out of specification, replace the valve lifter.
Valve lifter outside diameter: 7.9650mm

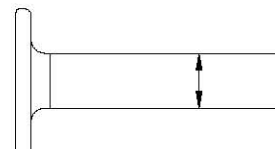

Oil splash gear

Inspect oil splash gear unit, if slow-moving/wear/damage/crack, replace.

Crankshaft bearing

Inspect bearing, if pitting/rumbling, replace.

NOTE:

Don't remove bearing unless you replace it.

Oil seal housing

1. Inspect oil seal housing for crack/damage. Replace if necessary.
2. Inspect O-ring for crack/damage. Replace if necessary.

Crankcase and crankcase cover

1. Inspect crankcase cover. If cracked/damaged, replace.
2. Inspect cooling water passage for dirt or clog. Clean if necessary.

FULL INSTALLATION

Piston connecting rod installation

Install piston, connecting rod, piston pin and piston pin circlip.

NOTE:

When installing, make sure that the mark on the connecting rod is at the same side of the mark on the piston crown.

Use new piston pin circlip. Make sure that circlip gap is not aligned with the circlip slot gap.

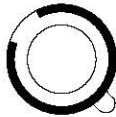

Piston ring installation

1. Install oil ring, 2nd ring and top ring.

NOTE:

Make sure that the mark is toward the piston crown when installing the 2nd ring.

2. Picture of the piston ring gap
 - Oil ring end gap 1 (lower rail)
 - Oil ring end gap 2 (expanded ring)
 - Oil ring end gap 3 (upper rail)
 - 2nd piston ring end gap 4
 - Top piston ring end gap 5

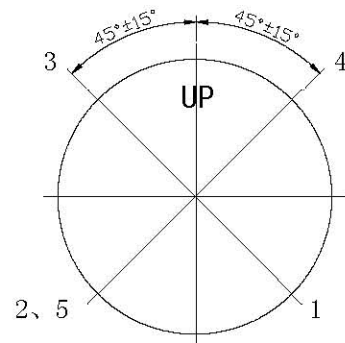

Piston installation

Use piston slider to install piston, and make sure the piston crown "UP" is toward the flywheel side.



NOTE:

Apply motor oil to the piston and piston ring side when installing.

Oil seal housing installation.

1. Install oil seals 10.8x21x7 (2 pieces) by oil seal installer tool.
2. Install oil seals B20 × 30 × 7 by oil seal installer tool.

NOTE:

- ① Apply grease onto new seal before installation.
- ② Make sure the oil seal direction as shown.

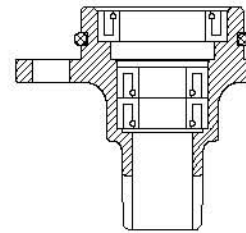

Crankshaft installation

1. Install the crankshaft bearing to crankcase by special tools (if change bearing). Install oil seal.



Housing bearing installer



Housing oil seal installer

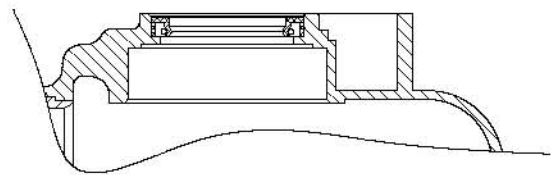

Oil seal installing direction

NOTE:

Fit the bearing with its manufacturer's mark toward the direction of the flywheel side. Apply motor oil to the new oil seal installing.

2. Install crankshaft to crankshaft case.
3. Install connecting rod cover, and tighten the connecting rod bolt to the specified torque.
Specified torque: 12 Nm

NOTE:

Apply motor oil to moving parts before installing.

Camshaft installation

Install camshaft. Make sure that the camshaft gear mark is aligned with the camshaft timing gear mark.

NOTE:

Apply motor oil to moving parts before installing.

Crankcase cover installation

1. Install oil seal housing.
2. Install oil splasher gear assembly.
3. Install crankcase cover, and tighten the bolts twice as shown.
Tightening torque: 1st 10 Nm
2nd 22 Nm

NOTE:

Apply motor oil to moving parts before installing.

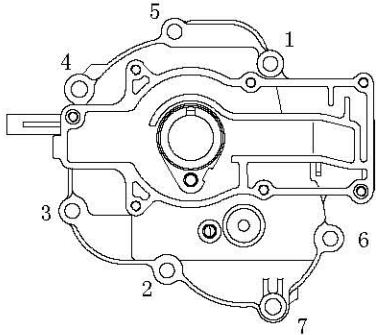

UPPER UNIT

TOP COWLING

EXPLOSIVE DRAWING

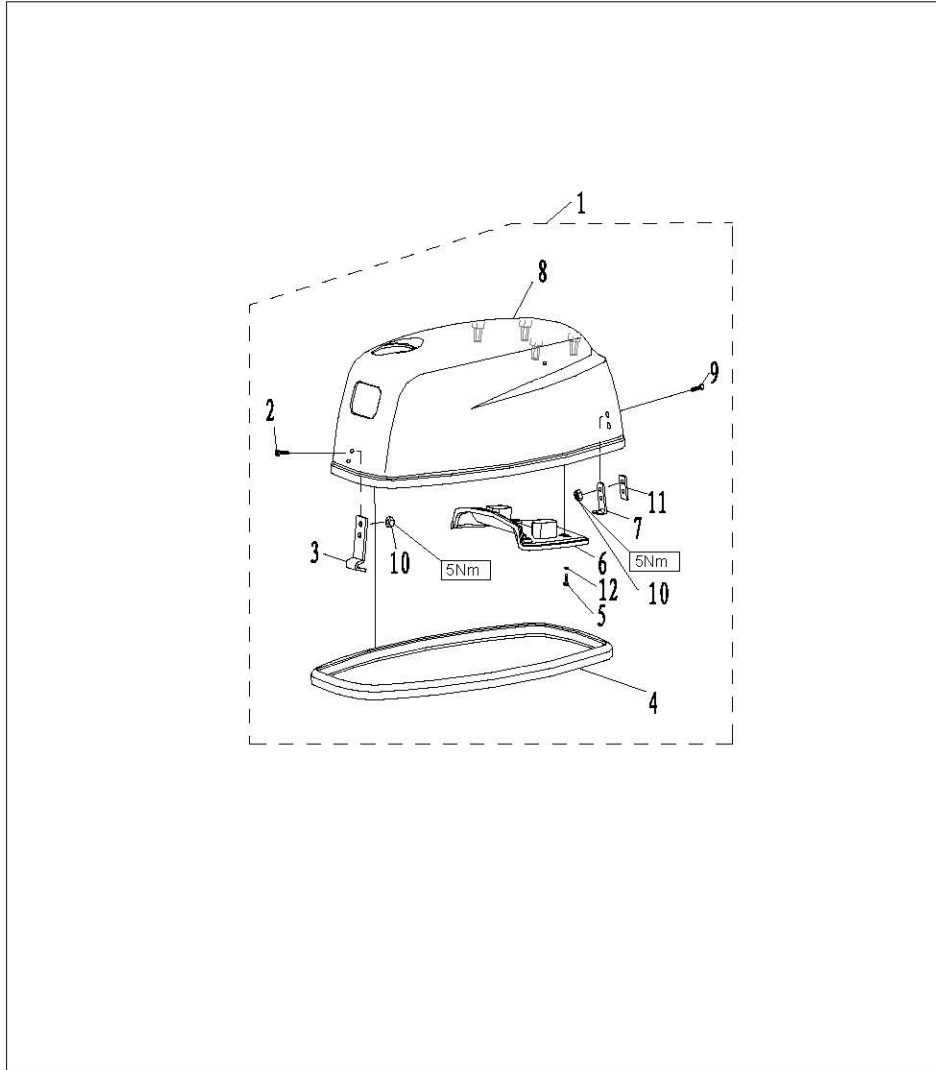

参照号码 SN.	零件编号 PART NO.	零件名称 DESCRIPTION	数量 QTY	备注 REMARKS
1	F4-06000000	顶罩组件 TOP COWLING ASSY	1	
2	GB/T8. 8-2000	十字槽盘头螺钉M5x12 SCREW, PAN HEAD	2	
3	F4-06000005	锁紧钩 HOOK, LOCK	1	
4	F4-06000002	密封橡胶条 BAR RUBBER, AIRPROOF	1	
5	GB/T845-85	十字槽盘头自攻螺钉TS. 5x19 SCREW, TAPPING	4	
6	F4-06000003	顶罩消音盖 COVER, TOPCOWING MUFFLING	1	
7	F15-08000004	挂钩 POTHOOK	1	
8	F4-06000001	顶罩 TOP COWLING	1	
9	GB/T818-2000	十字槽盘头螺钉M5x20 SCREW, PAN HEAD	2	
10	GB/T6172.1-2000	六角锁紧螺母M5 THIN NUT, HEXAGON	2	

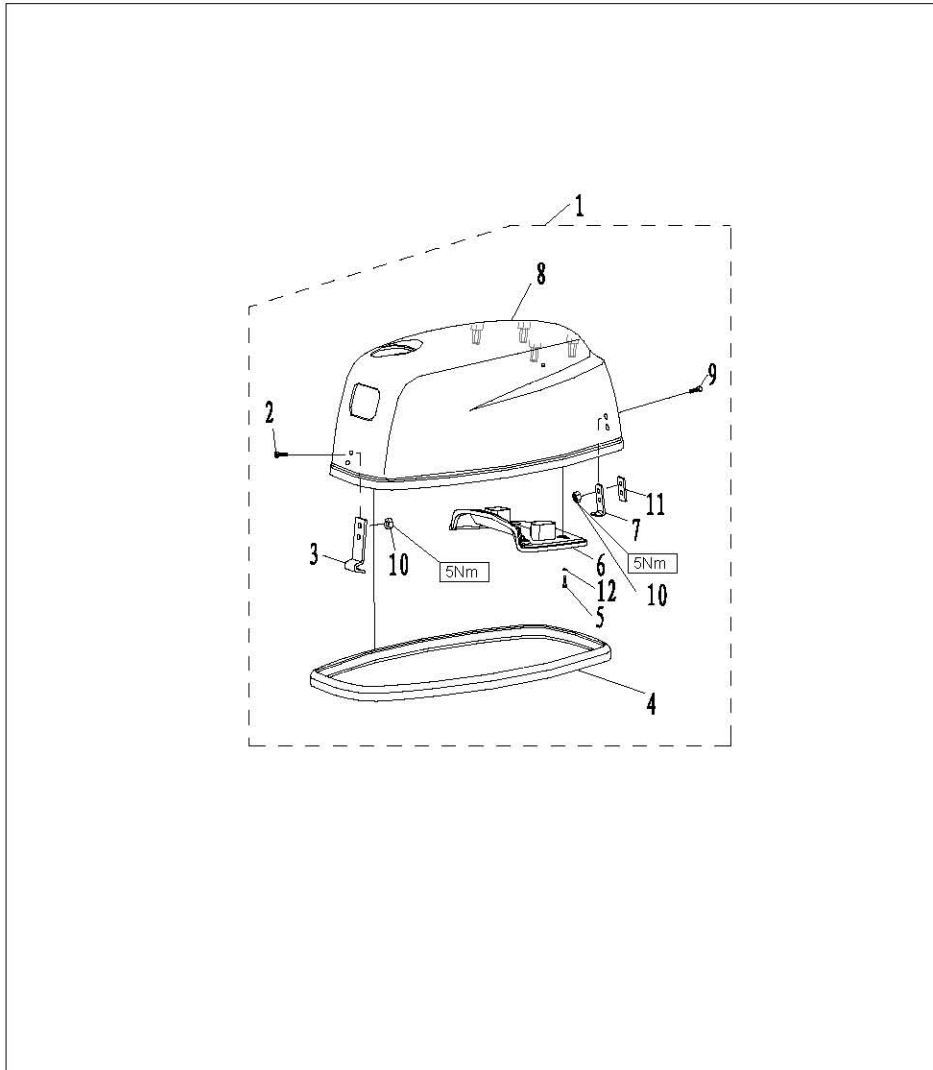

参照号码 SN.	零件编号 PART NO.	零件名称 DESCRIPTION	数量 QTY	备注 REMARKS
11	F4-06000006	挂钩垫 UNDERLAY, POTBOOK	1	
12	F4-06000004	橡胶垫片 UNDERLAY, RUBBER	4	

Disassembling and inspection

1. Remove airproof rubber bar.
2. Remove top cowling muffling cover bolt and rubber underlay.
3. Remove top cowling muffling cover.
4. Remove lock hook and pothook.
5. Inspect if top cowling is cracked or damaged. Replace it if necessary.
6. Inspect if airproof rubber bar is cracked or damaged. Replace it if necessary.
7. Inspect if top cowling muffling cover is cracked or damaged. Replace it if necessary.
8. Inspect if lock hook and pothook is cracked, deformed or damaged. Replace it if necessary.

BOTTOM COWLING

Explosive drawing

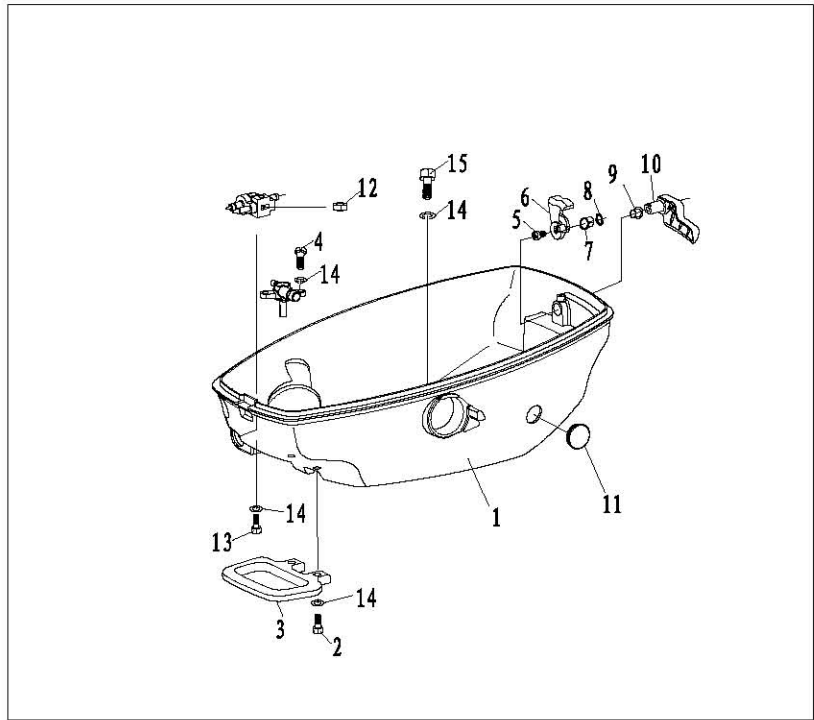

参照号码 SN.	零件编号 PART NO.	零件名称 DESCRIPTION	数量 QTY	备注 REMARKS
1	F4-0500001	底罩 COWLING, BOTTOM	1	
2	GB/T818-2000	十字槽盘头螺钉M6x14 CROSS, PAN HEAD BOLT	2	
3	F4-0500016	手把 HANDLE	1	
4	GB/T818-2000	十字槽盘头螺钉M6x12 CROSS, PAN HEAD BOLT	2	
5	GB/T5783-86	六角头螺栓M6x12 BOLT	1	
6	F15-05030000	顶罩锁紧块组件 LEVER, CLAMP	1	
7	F15-05000022	顶罩锁紧手柄尼龙套A BUSH A	1	
8	F15-05000023	波形垫圈 WASHER, WAVE	1	
9	F15-05000036	顶罩锁紧手柄尼龙套B BUSH B	1	
10	F4-0500012	顶罩锁紧手柄 LEVER, CLAMP	1	

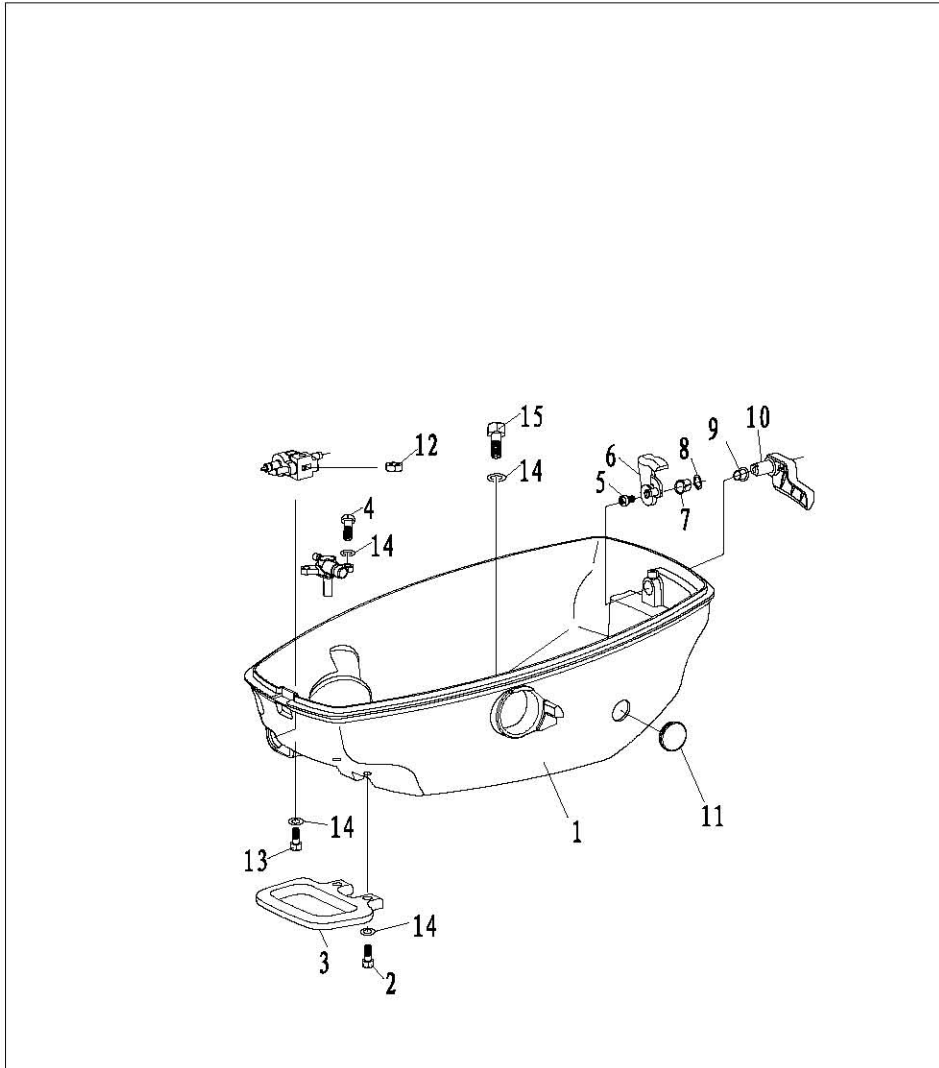

参照号码 SN.	零件编号 PART NO.	零件名称 DESCRIPTION	数量 QTY	备注 REMARKS
11	F4-05000013-2	橡胶阿盖B COVER, RUBBER	1	
12	GB/T6170-86	六角螺母M6 NUT, HEXAGON	1	
13	GB/T5783-2000	六角头螺栓M6x25 BOLT, HEXAGON	1	
14	GB/T97.1-85	平垫圈6 WASHER	12	
15	GB/T5783-2000	六角头螺栓M6x14 BOLT, HEXAGON	7	

Disassembling and inspection

1. Remove rubber cover B.
2. Remove handle bolt and handle.
3. Remove top cowling clamp lever bolt and clamp lever.

4. Remove top cowling clamp lever bush A and clamp lever bush B.
5. Remove wave washer.
6. Inspect if bottom cowling is cracked or damaged. Replace if necessary.
7. Inspect if clamp lever handle is cracked or damaged. Replace if necessary.
8. Inspect if clamp lever is cracked or damaged. Replace if necessary.
9. Inspect if wave washer and clamp lever bush are cracked or damaged. Replace if necessary.

STEERING HANDLE

Explosive drawing

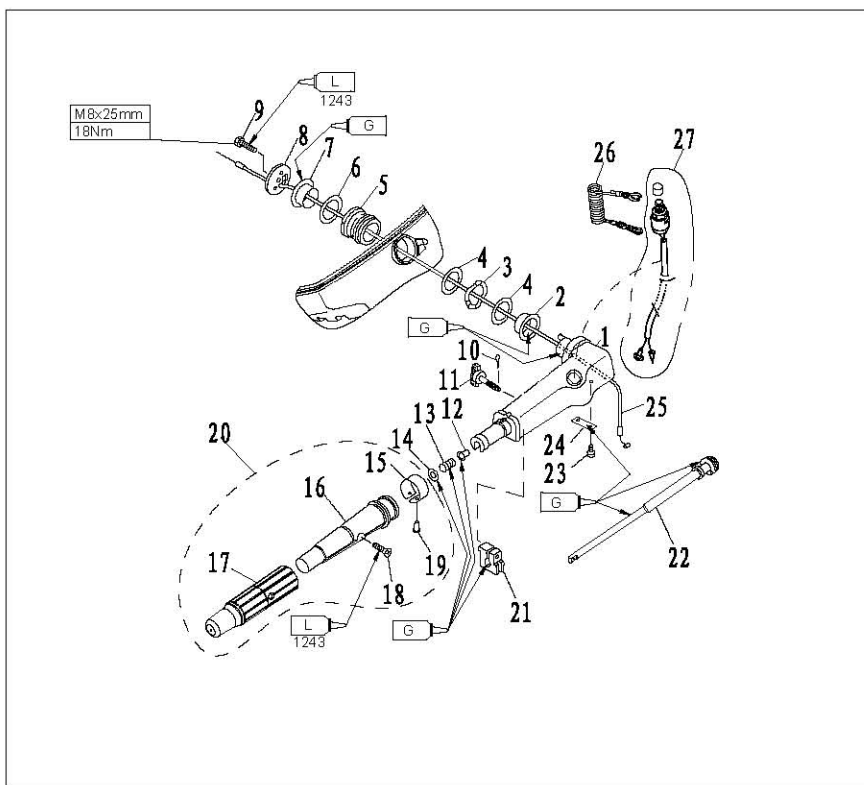

参照号码 SN.	零件编号 PART NO.	零件名称 DESCRIPTION	数量 QTY	备注 REMARKS
1	F4-01090001	操舵手柄 HANDLE, STEERING	1	
2	F4-01000009	手柄衬套A BUSHING, HANDTE A	1	
3	F4-01000012	手柄衬套波形垫圈 BUSH	1	
4	F4-01000010	衬套垫圈B WASHER, BUSHING B	2	
5	F4-05000014	操舵手柄减震器 BUSHING, RABBER	1	
6	F4-01000011	衬套垫圈A WASHER BUSHING A	1	
7	F4-01000008	操舵手柄衬套B BUSHING	1	
8	F4-01000014	操舵手柄盖板 COVER, HANDLE STEERING	1	
9	GB/T5783-2000	六角头螺栓M8x25 BOLT	1	
10	GB/T91-86	开口销φ1.6x12 PIN, COTTER	1	

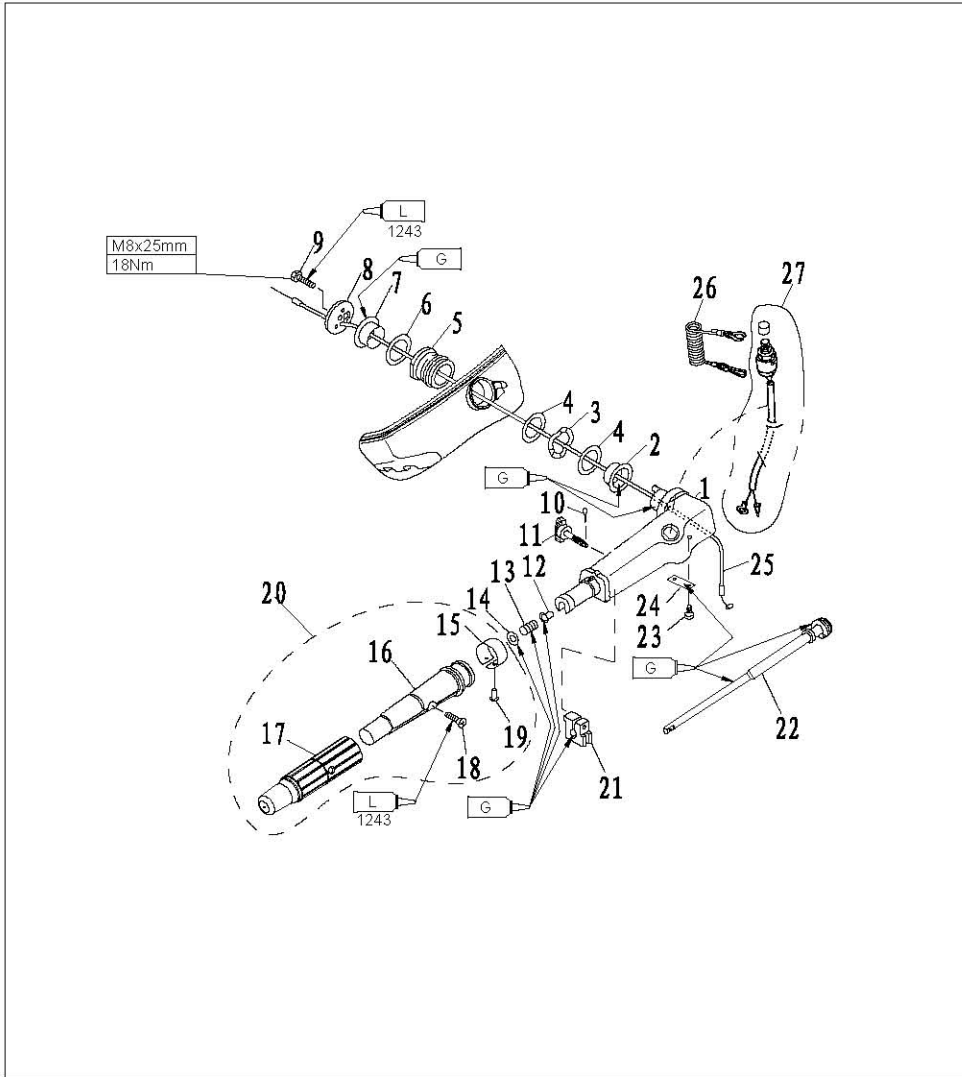

参照号码 SN.	零件编号 PART NO.	零件名称 DESCRIPTION	数量 QTY	备注 REMARKS
11	F4-01090200	阻力调整旋钮组件 BOLT, FRICTION ADJUSTING	1	
12	F4-01090006	衬套 BUSH	1	
13	F4-01090007	压缩弹簧 SPRING, COMPRESSION	1	
14	GB/T848-85	小垫圈10 WASHER, PLATE	1	
15	F4-01090303	油门标志牌 INDICATOR THROTTLE	1	
16	F4-01090301	操舵手柄塑胶套 GRIP, STEERING HANDLE	1	
17	F4-01090302	操舵手柄橡胶套 RUBBER, HANDLE	1	
18	GB/T820-85	十字槽半沉头螺钉M5x24 SCREW	1	
19	GB/T827-86	标牌铆钉2x5 RINET	1	
20	F4-01090300	油门握把组件 STEERING HANDLE ASSY	1	

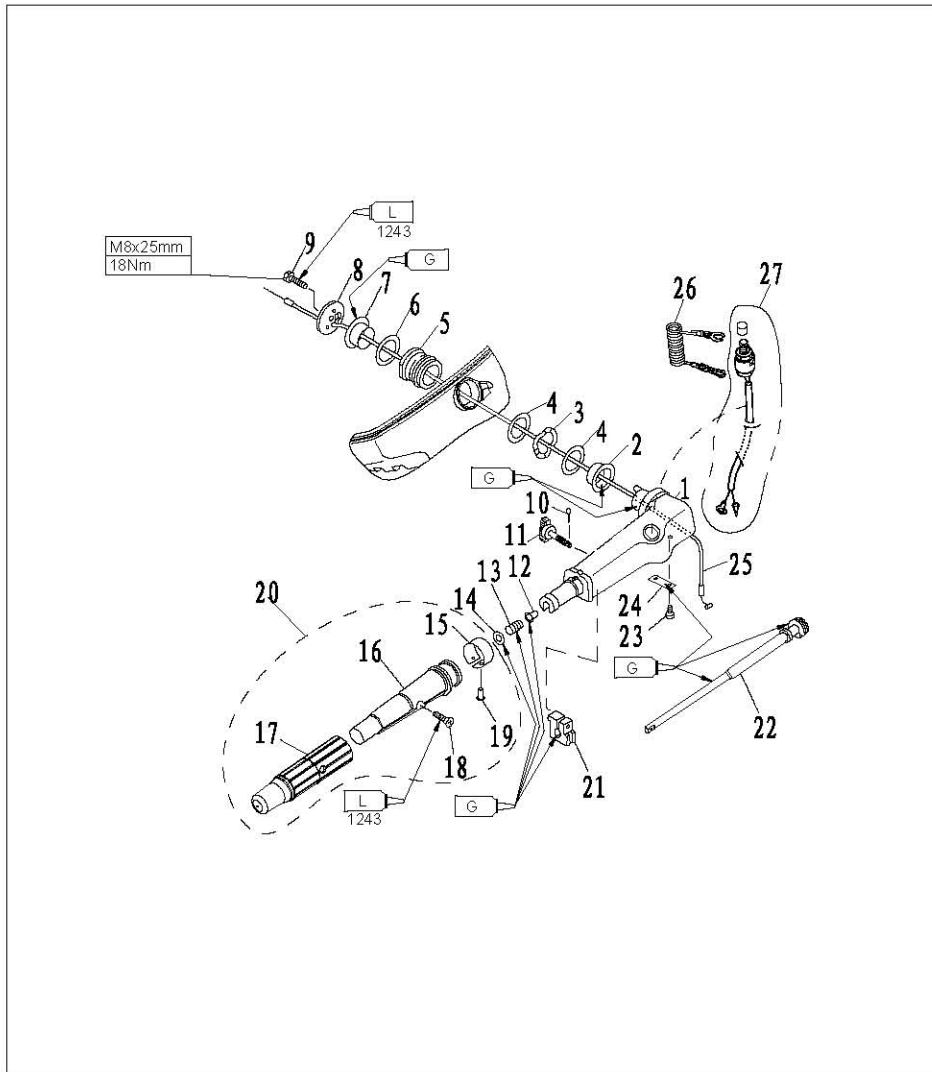

参照号码 SN.	零件编号 PART NO.	零件名称 DESCRIPTION	数量 QTY	备注 REMARKS
21	F4-01090003	操舵手柄握把摩擦块 FRICTION	1	
22	F4-01090100	节气门杆组件 LEVER, THROTTLE	1	
23	GB/T818-85	十字槽盘头螺钉M5x12 SCREW, PAN HEAD	2	
24	F4-01090002	节气门杆固定板 STAY	1	
25	F4-01090008	油门钢索组件 THROTTLE CABLE ASSY	1	
26	F4-01090401	引擎停止安全索 STOPER, HANG ROPE ASSY	1	
27	F4-01090400	急停开关组件 ENGINE STOP SWITCH ASSY	1	

Disassembling and inspection

1. Remove steering handle cover.
2. Remove handle bush, bush washer and wave washer.
3. Remove steering handle shocker damper.

4. Remove cotter pin and friction adjusting bolt.
5. Remove steering handle.
6. Remove throttle cable.
7. Remove throttle lever stay and throttle lever.
8. Remove engine stop switch.
9. Inspect if steering handle is cracked or damaged. Replace if necessary.
10. Inspect if bush, bush washer and wave washer are cracked or damaged. Replace if necessary.

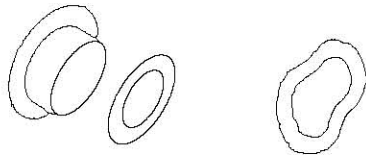

11. Inspect if steering handle shock damper is cracked or damaged. Replace if necessary.

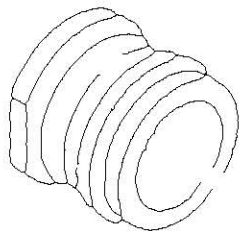

12. Inspect if throttle cable is cracked or damaged. Replace if necessary.

13. Inspect the conduction of engine stop switch. If not to specification, replace it.

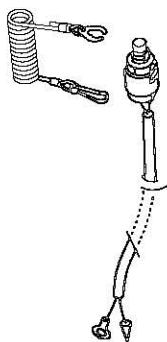

Remove lockplate: Conducting
 Install lockplate: Not conducting
 Push stop switch button: Conducting

BRACKET

Explosive drawing

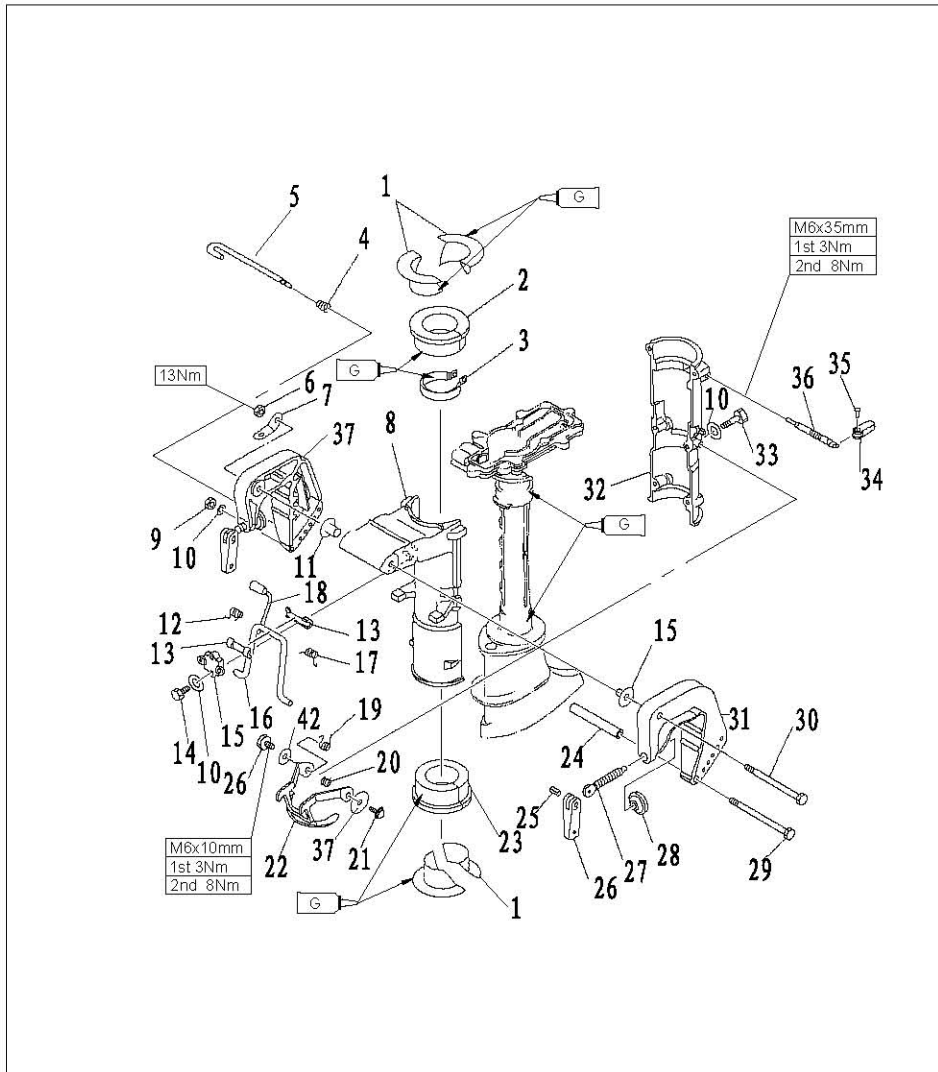

参照号码 SN.	零件编号 PART NO.	零件名称 DESCRIPTION	数量 QTY	备注 REMARKS
1	F4-02000008	减震圈衬管 BUSH ,SHOCK ABSORPTION	4	
2	F4-02000007	上减震圈 TOP ,SHOCK ABSORPTION	1	
3	F4-02020000	水上装置锁紧圈组件 UPPER LOCKING RING ASSY	1	
4	F4-01050002	锥形弹簧 SPRING ,CONICAL	1	
5	F4-01050000	角度调整杆组件 TILT ROD ASSY	1	
6	GB/T889.1-2000	非金属嵌件六角锁紧螺母M8 NUT	1	
7	F4-01000002	双孔固定板 PLATE	2	
8	F4-01030001	旋转支架座 BRACKET ,SWIVEL	1	
9	GB/T6170-86	六角螺母M6 HEXAGON NUT	1	
10	GB/T97.1-85	平垫圈6 WASHER	11	

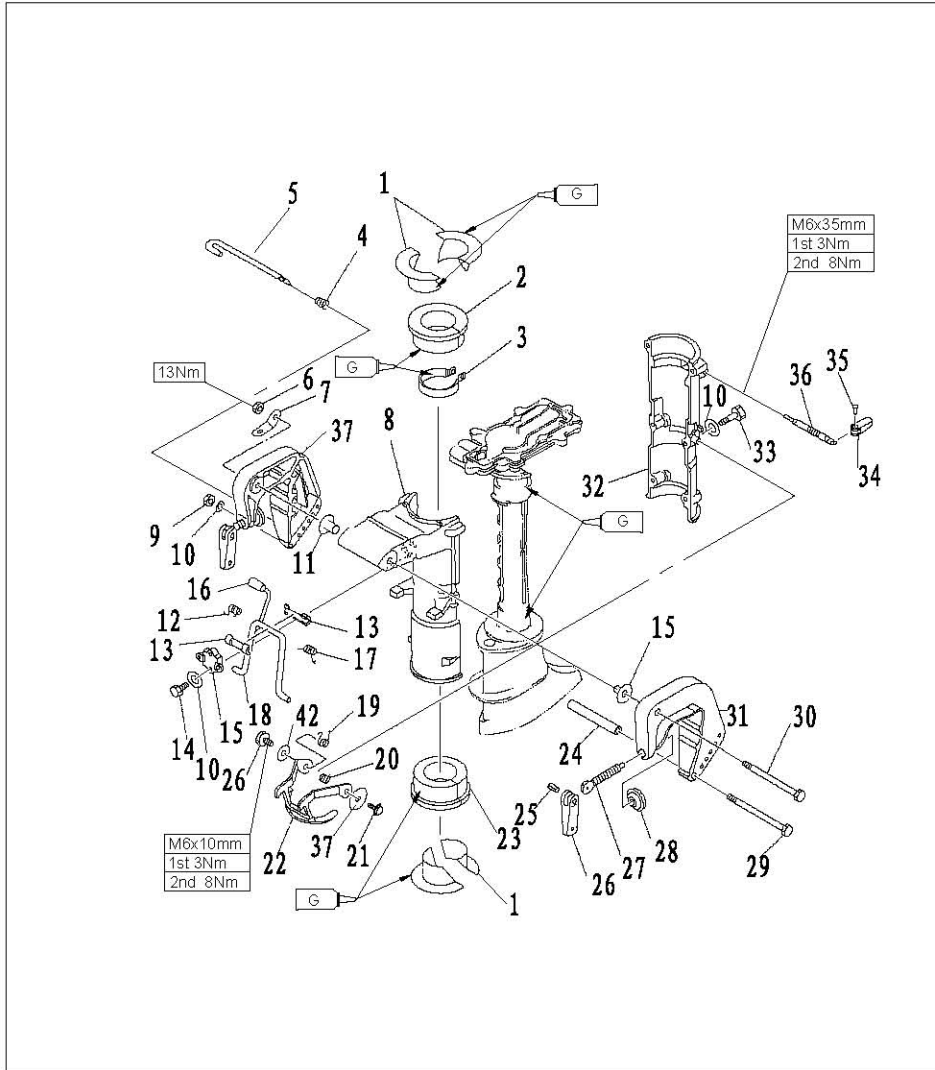

参照号码 SN.	零件编号 PART NO.	零件名称 DESCRIPTION	数量 QTY	备注 REMARKS
11	F4-01000003	尼龙垫圈 WASHER, NYLON	2	
12	F4-01030003	支撑架扭簧(左) SPRING, TORSION (LEFT)	1	
13	F4-01030002	支撑架尼龙衬套 BUSHING, NYLON	2	
14	GB/T5783-2000	六角头螺栓M6×20 HEXAGON, BOLT	2	
15	F4-01030005	支撑架固定盖 FIXED COVER, BRACKET	1	
16	F4-01030103	手柄套 SHEATH HANDLE	2	
17	F4-01030004	支撑架扭簧(右) SPRING, TORSION (RIGHT)	1	
18	F4-01030100	角度定位支撑架组件 BRACKET, TILT LOCK	1	
19	F4-01000006	锁紧钩扭簧(左) SPRING	1	
20	F4-01000007	锁紧钩扭簧(右) SPRING	1	

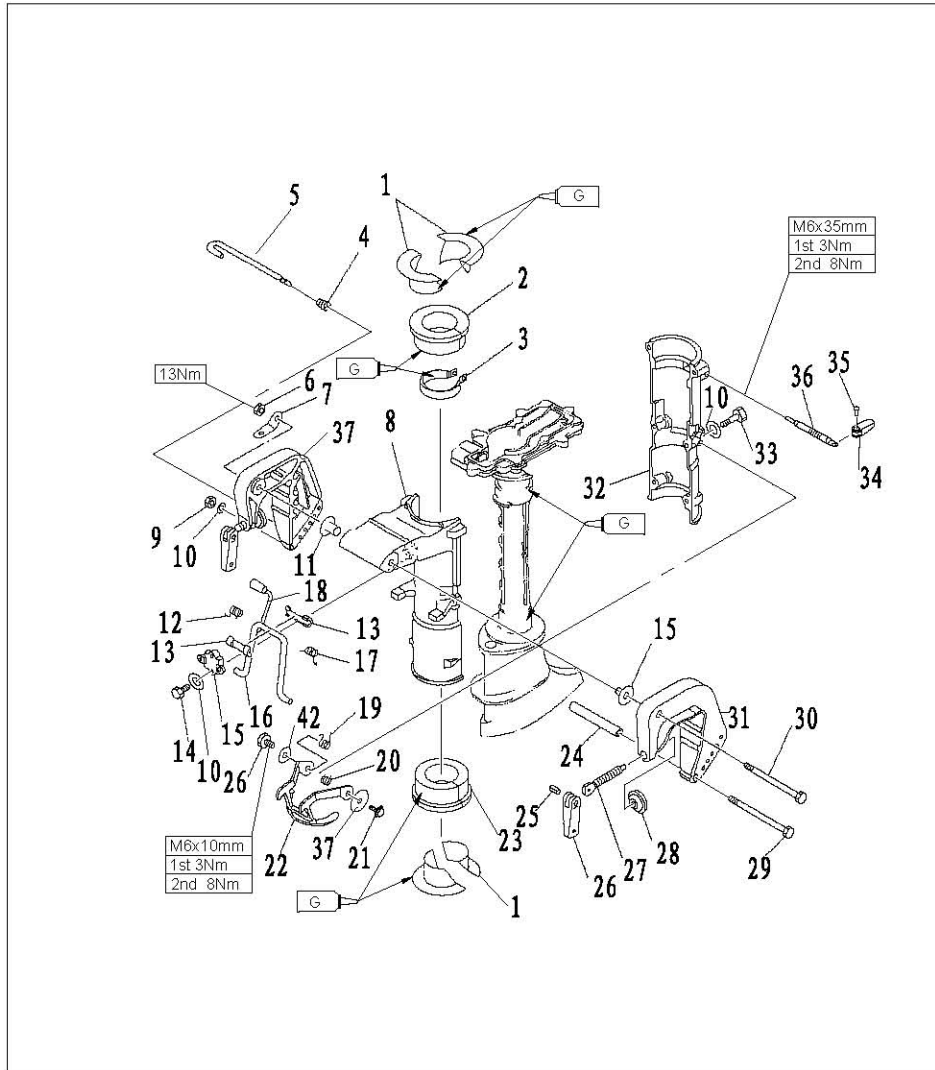

参照号码 SN.	零件编号 PART NO.	零件名称 DESCRIPTION	数量 QTY	备注 REMARKS
21	GB/T5783-2000	六角头螺栓M6×12 HEXAGON BOLT	2	
22	F4-01070000	起翘锁紧钩组件 TILT LOCKED CLASP ASSY	1	
23	F4-02000009	下减震圈 BOTTOM ABSORPTION ASSY	1	
24	F4-01000004	螺栓垫管 BUSHER, BOLT	1	
25	F4-01010005	舰板夹紧手柄铆钉 RIVET, CLAMP HANDLE	2	
26	F4-01010004	舰板夹紧手柄 CLAMP SHIPBOARD HANDLE	2	
27	F4-01010002	舰板夹紧螺杆 CLAMP BOLT	2	
28	F4-01010003	舰板夹紧圆盘 CLAMP PLATE	2	
29	GB/T5782-2000	六角螺栓M6×120 HEXAGON BOLT	1	
30	GB/T5782-2000	六角螺栓M8×135 HEXAGON BOLT	1	

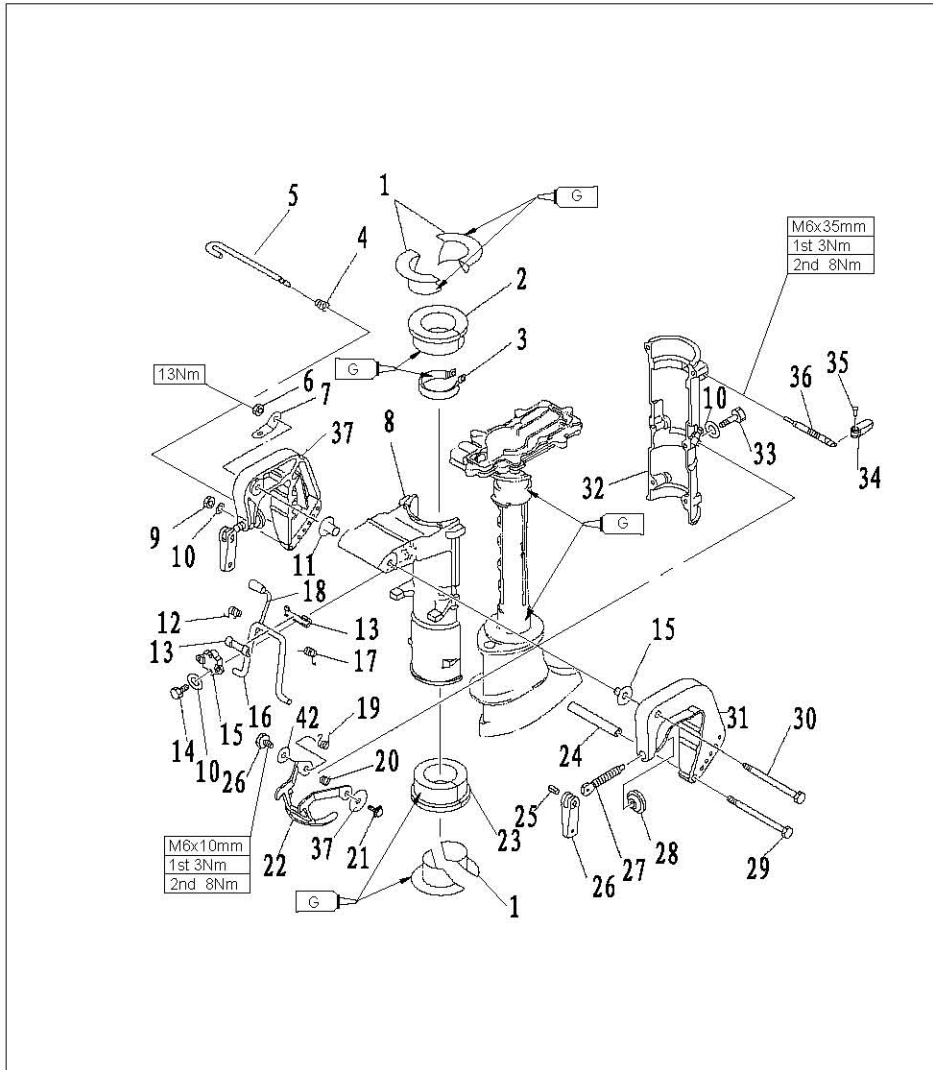

参照号码 SN.	零件编号 PART NO.	零件名称 DESCRIPTION	数量 QTY	备注 REMARKS
31	F4-01010001	夹紧托架(右) BRACKET, CLAMP (RIGHT)	1	
32	F4-01000005	旋转支架座盖 COVER, SWIVEL BRACKET	1	
33	GB/T5782-86	六角头螺栓M6x35 HEXAGON BOLT	6	
34	F4-01060002	锁紧手柄 CLAMP HANDLE	1	
35	GB/T875-86	扁平头半空心铆钉φ4x11 RIVET	1	
36	F4-01060001	锁紧螺杆 LOCKED SCREW	1	
37	GB/T96-1985	大垫圈 BIG WASHER	2	
38	F4-01020000	夹紧托架(左)组件 BRACKET LEFT ASSY	1	

Disassembling and inspection

1. Remove tilt locked clasp.
2. Remove swivel bracket cover.
3. Remove bottom shock absorption assembly and shock absorption bush.

4. Remove clamp bracket
5. .Remove swivel bracket.
6. Remove bracket fixed cover, and the tilt lock bracket.
7. Inspect the the swivel bracket and clamp bracket for damage or crack. Replace if necessary.

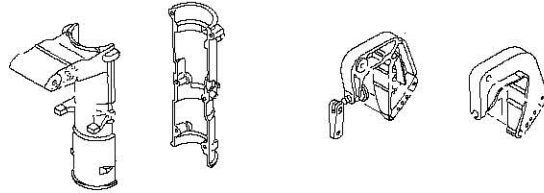

8. Inspect the bush and shock absorption for damage or crack. Replace if necessary.

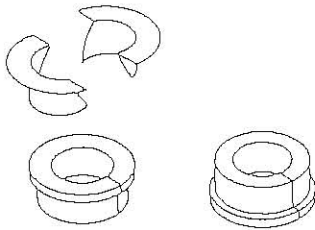

9. Inspect: whether the tilt lock bracket and tilt locked clasp were distorted, replace if needed.

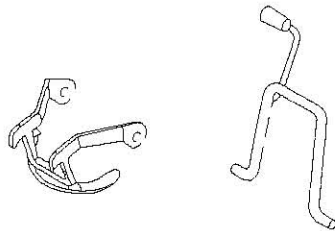

UPPER UNIT

Explosive drawing

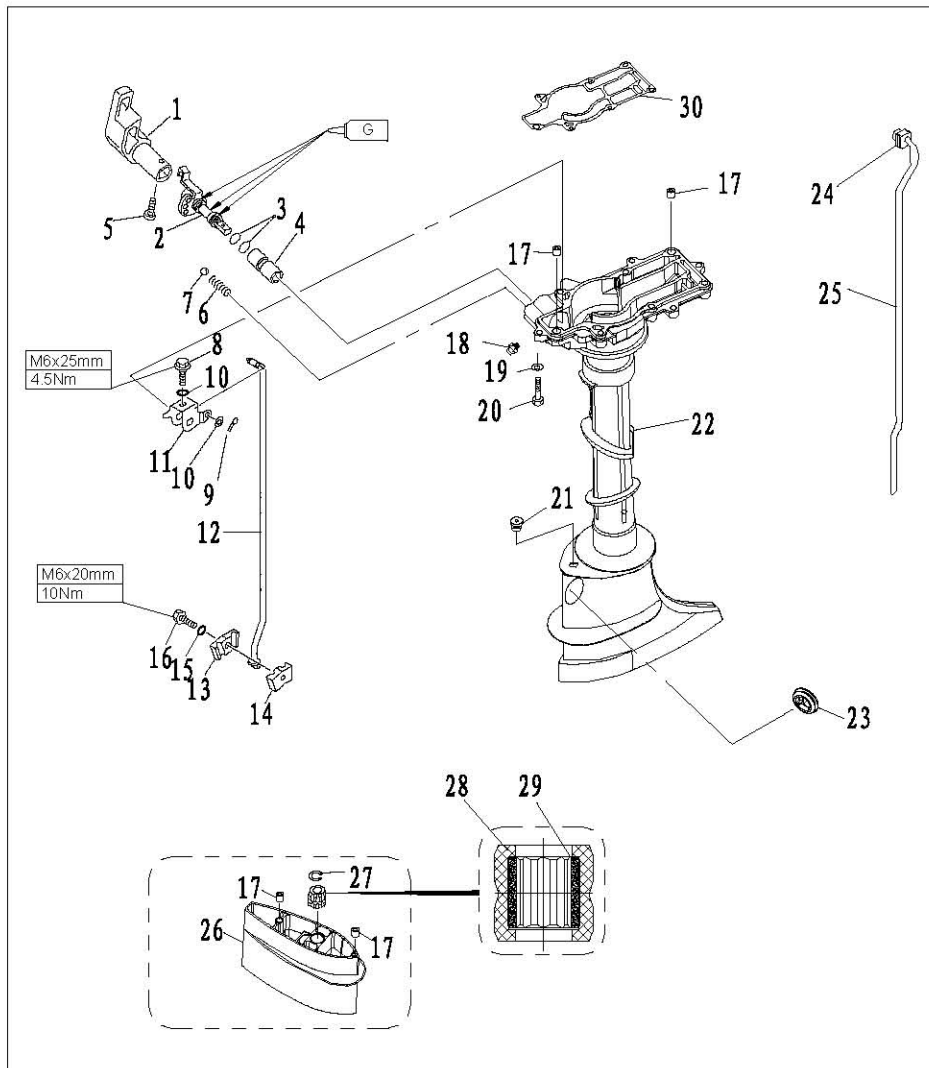

参照号码	零件编号	零件名称	数量	备注
SN.	PART NO.	DESCRIPTION	QTY	REMARKS
1	F4-00000007	变档手柄 HANDLE, GEAR SHIFT	1	
2	F4-02010000	变档拨叉组件 SHAFT, CHANGE	1	
3	JISB2401	"O"形密封圈P9 O-RING	2	
4	F4-02000002	水上装置壳体铜套 BUSHING, SHIFT ROD LEVER	1	
5	GB/T820-2000	十字半沉头螺钉M5x20 SCREW, OVAL HEAD	1	
6	F4-02000003	变档弹簧 SPRING, GEAR	1	
7	GB308-84	钢珠8 BALL 8	1	
8	GB/T5783-2000	六角螺栓M5x25 BOLT	1	
9	GB/T308-84	开口销1.6x12 PIN, COTTER	1	
10	GB/T97.1	平垫圈5 WASHER, PLATE 5	2	

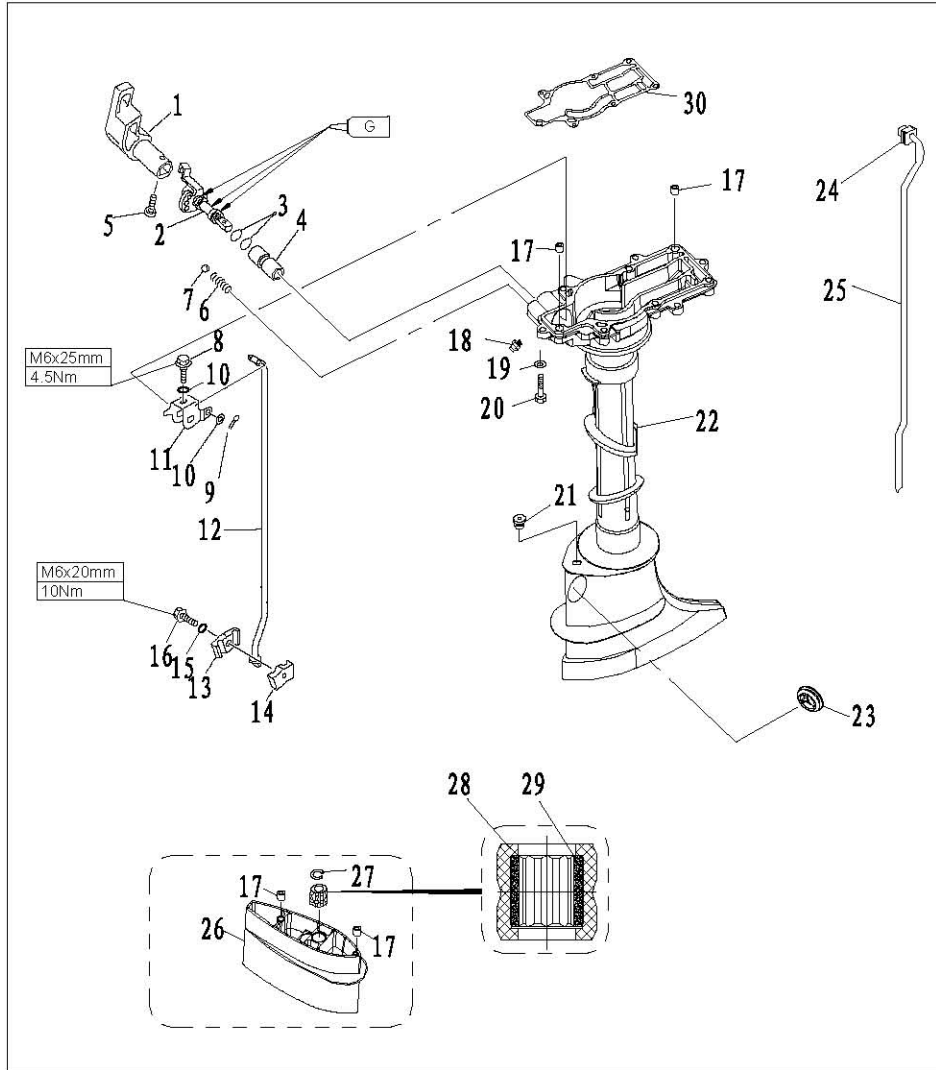

参照号码 SN.	零件编号 PART NO.	零件名称 DESCRIPTION	数量 QTY	备注 REMARKS
11	F4-02000006	变档连杆支架 LEVER, SHIFT ROD	1	
12	F4-02000004	变档连杆 ROD, SHIFT	1	
13	F4-00000003	变档连杆连接器A CONNECTOR, SHIFT ROD A		
14	F4-00000004	变档连杆连接器B CONNECTOR, SHIFT ROD B		
15	F4-00000005	大垫圈 BIG, WASHER	1	
16	GB/T5284-86	六角头螺栓M6x20 BOLT	1	
17	F4-00000001	空心定位销 PIN ,HOLLOW	4	Type S: 2
18	JB/T7940.1-95	直通式压注油杯M6 GREASE CUP	1	
19	GB/T97.1-85	平垫圈6 WASHER	7	
20	GB/T5284-86	六角头螺栓M6 × 35 HEXAGON BOLT	7	

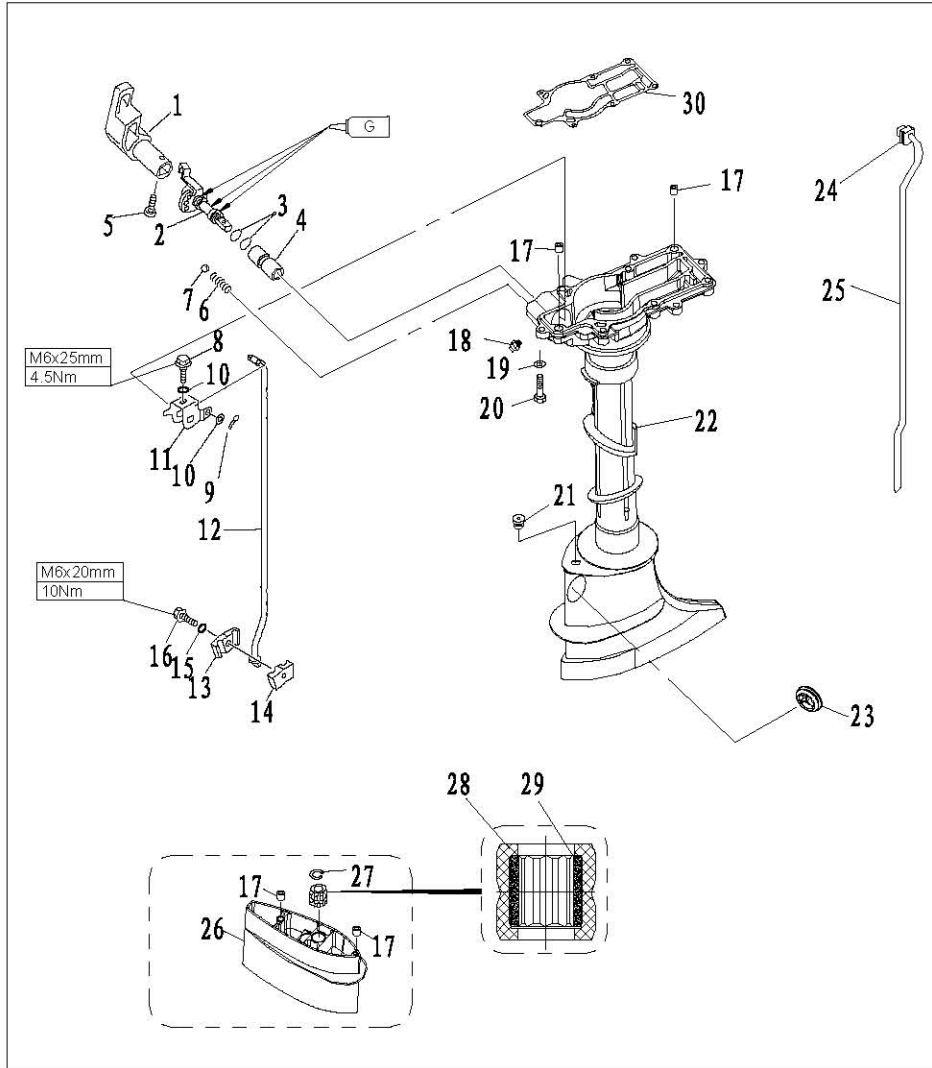

参照号码 SN.	零件编号 PART NO.	零件名称 DESCRIPTION	数量 QTY	备注 REMARKS
21	F4-02000011	变档轴密封圈 WASHER, SHIFT ROD	1	
22	F4-02000001	水上装置壳体 CASING, UPPER	1	
23	F4-02000012	水上装置橡胶堵头 RUBBER PLUG, UPPER	2	
24	F4-02040002	工形橡胶圈 I-SHAPED RUBBER BAND	1	
25	F4-02040000	进水管 WATER TUBU	1	Type S: F4-02040000S
26	F4-02030001	接长体 EXTENSION	1	L
27	GB/T 893.1-1986	孔用弹性挡圈 CIRCLIP	1	L
28	F4-02030003	驱动轴橡胶衬套 RUBBER BUSHING	1	L
29	F4-02030002	驱动轴衬套 BUSHER, DRIVE SHAFT	1	L
30	F4-00000006	发动机密封垫 GASKET, ENGINE		

Disassembling and inspection

1. Remove the water tube.
2. Remove the gear shift handle and change shaft.
3. Remove the shift rod and shift rod lever.

4. Check upper casing and extension for crack or wear. Replace if necessary.

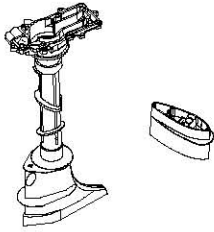

5. Check gear shift handle and change shaft for crack or wear. Replace if necessary.

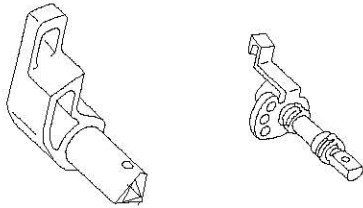

LOWER UNIT

WATER PUMP ASSEMBLY

Explosive drawing

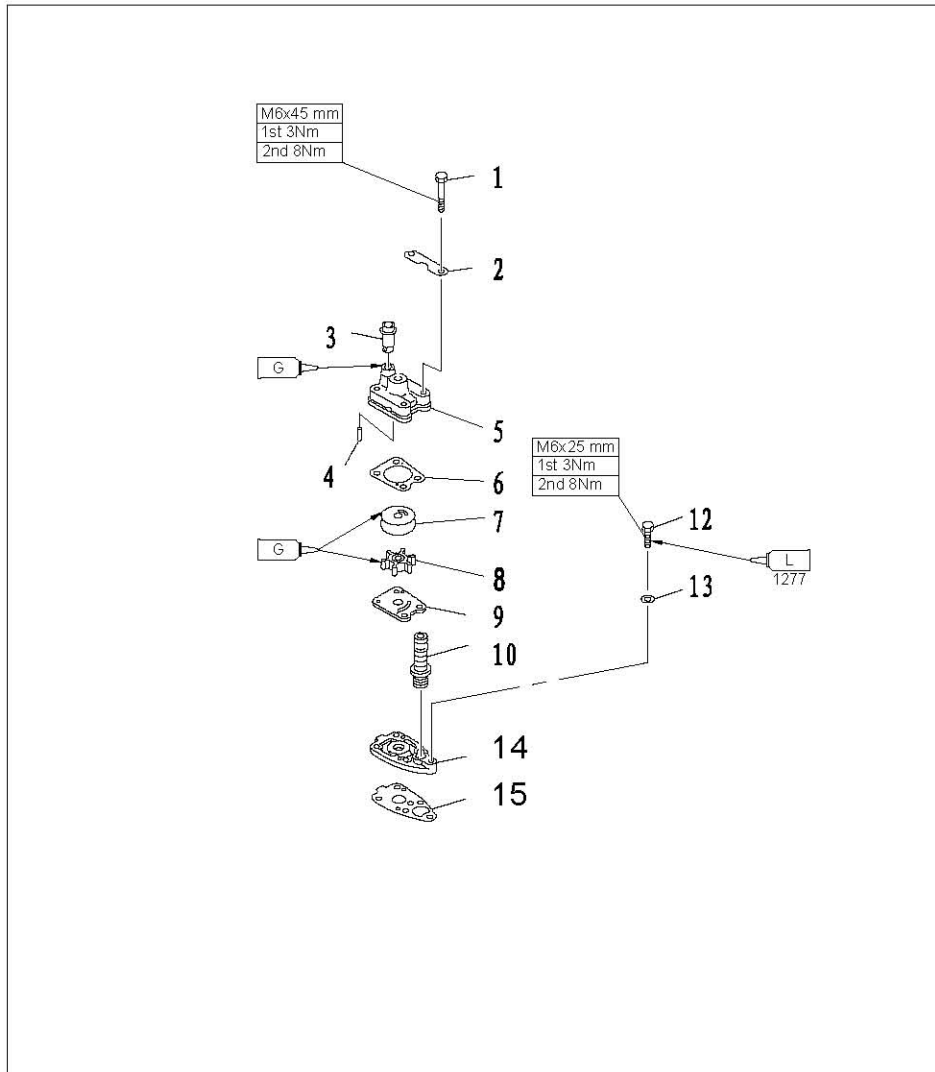

参照号码 SN.	零件编号 PART NO.	零件名称 DESCRIPTION	数量 QTY	备注 REMARKS
1	GB/T5782-2000	六角头螺栓M6 × 45 HEXAGON BOLT	4	
2	F4-03000020	泵壳固定板 PLATE, WATER PUMP FIXED	2	
3	F4-03000021	泵壳橡胶管 RUBBER TUBE, WATER PUMP	1	
4	F4-03000013	水泵座定位销 PIN, WATER PUMP	2	
5	F4-03000019	水泵壳 HOUSING, WATER PUMP	1	
6	F4-03000018	泵壳密封垫 GASKET, WATER PUMP COVER	1	
7	F4-03000017	水泵内壳 COVER, INNER WATER PUMP	1	
8	F4-03060000	水泵叶轮 IMPELLER, WATER PUMP	1	
9	F4-03000015	外档板 OUT PLATE	1	
10	F4-03000014	变档橡胶护套(含弹簧) RUBBER JACKET, SHIFT ROD	1	

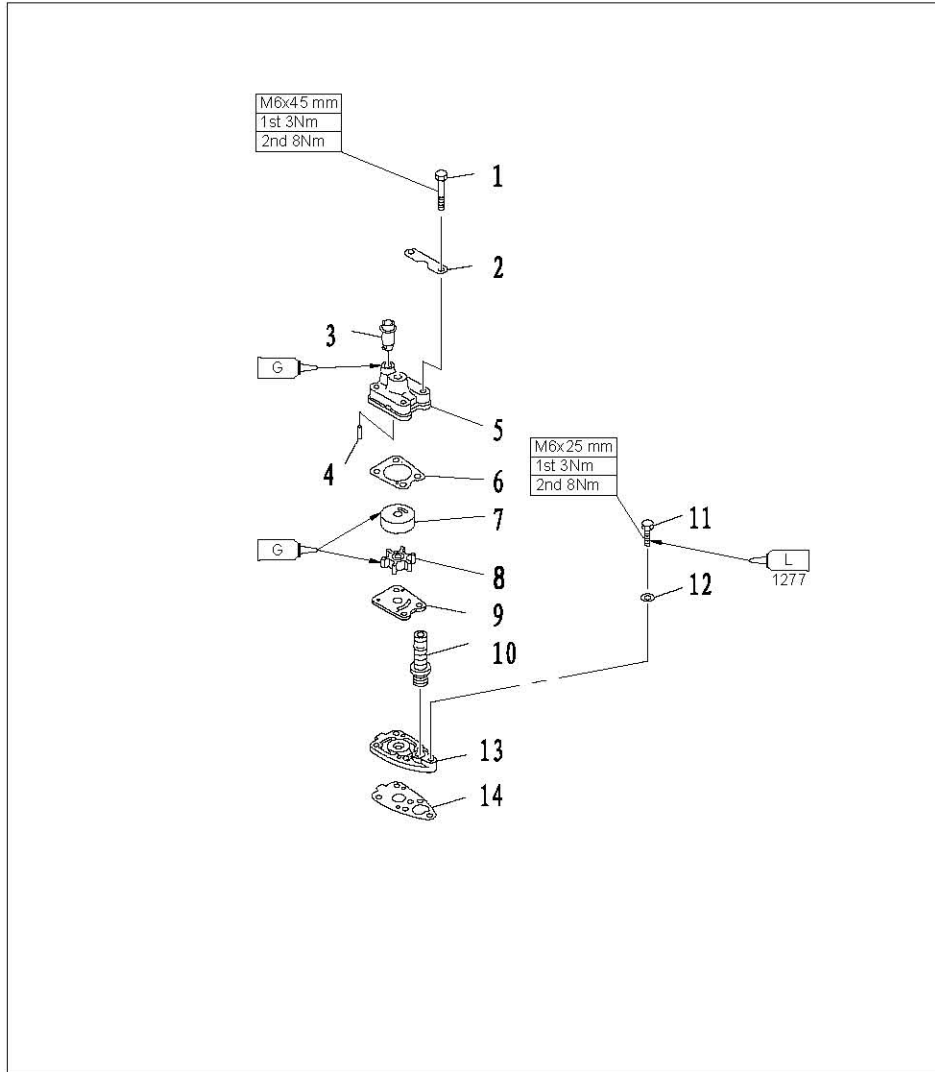

参照号码 SN.	零件编号 PART NO.	零件名称 DESCRIPTION	数量 QTY	备注 REMARKS
11	GB/T5783-2000	六角头螺栓M6×25 HEXAGON BOLT	1	
12	GB/T97.1-85	平垫圈6 WASHER, PLATE	5	
13	F4-03000012	水泵座 BASE, WATER PUMP	1	
14	F4-03000011	水泵座密封垫 HERMETIC GASKET	1	

Disassembling and inspection

1. Remove water pump fixed plate.
2. Remove water pump housing.
3. Remove water pump impeller and inner water pump cover.
4. Remove water pump base.

5. Check water pump housing and out plate for crack, crank or damage. Replace if necessary.

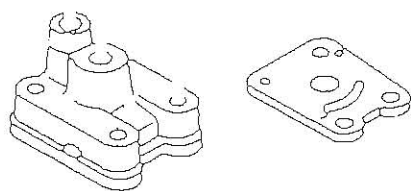

6. Check inner water pump cover and impeller for crack, deform, burn or damage. Replace if necessary.

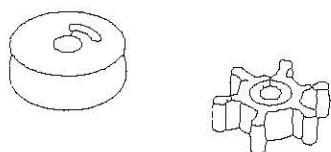

7. Check water pump base for crack, crank, scratch or damage. Replace if necessary.

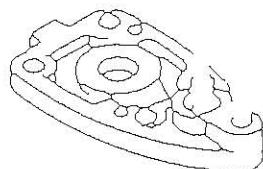

LOWER UNIT
Explosive drawing

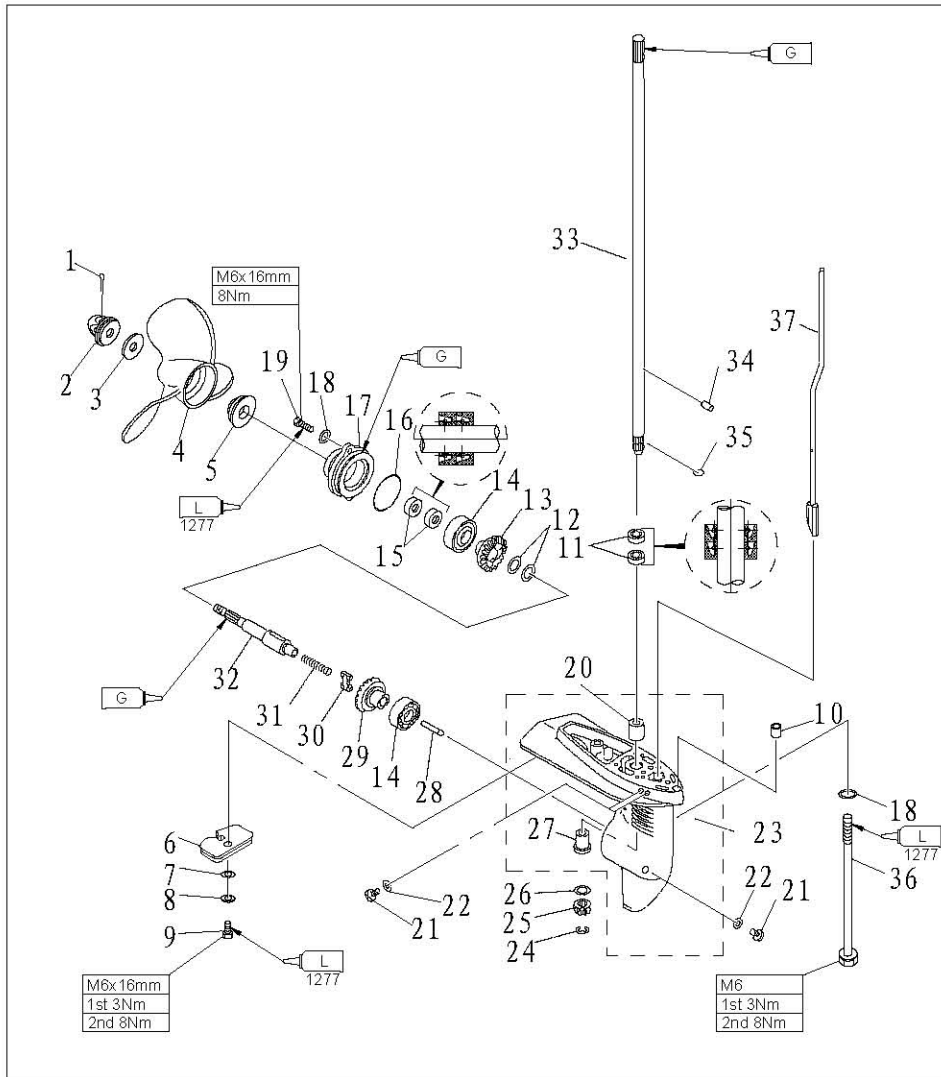

参照号码	零件编号	零件名称	数量	备注	
SN.	PART NO.	DESCRIPTION	QTY	REMARKS	
1	GB/T91-86	开口销2.5×30	PIN ,COTTER	1	
2	F4-03080000	螺母组件	NUT ASSY	1	
3	F4-03000026	不锈钢垫片	WASHER	1	
4	F4-03070000	螺旋桨组件	PROPELLER ASSY	1	
5	F4-03000025	不锈钢垫块	SPACER	1	
6	F4-03000022	阳极	ANODE	1	
7	GB/T97.1-85	平垫圈6	WASHER ,PLATE	1	
8	GB/T861.1-87	内齿锁紧垫圈6	WASHER, INTERNAL TOOTH	1	
9	GB/T5783-2000	六角头螺栓M6×12	HEXAGON BOLT	1	
10	F4-00000001	空心定位销	HOLLOW PIN	2	

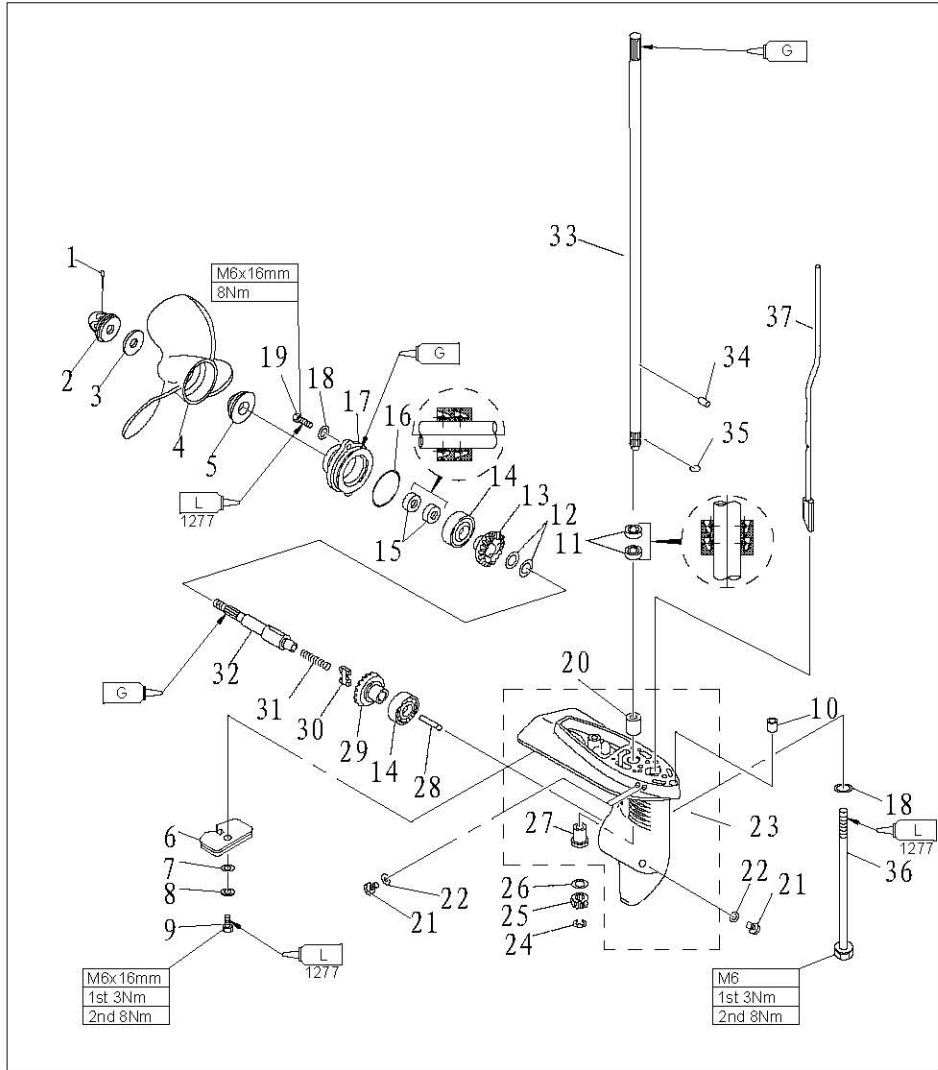

参照号码 SN.	零件编号 PART NO.	零件名称 DESCRIPTION	数量 QTY	备注 REMARKS
11	F4-03000027	油封 10.8×21×7 OIL SEAL	2	
12	F4-03000009	倒档齿轮垫圈 WASHER ,REVERSE GEAR	2	
13	F4-03040000	倒档齿轮组件 REVERSE GEAR ASSY	1	
14	GB/T276-94	深沟球轴承6004C2 BEARING	2	
15	F4-03050002	油封13×22×7 OIL SEAL	2	
16	JISB2401 P48	水下装置壳体盖O形圈 O-RING	1	
17	F4-03050001	水下装置壳体盖 COVER ,LOWER CASING	1	
18	GB/T97.1-85	平垫圈6 WASHER ,PLATE	5	
19	GB/T5783-2000	六角头螺栓M6×18 HEXAGON BOLT	2	
20	F4-03000003	不带档边筒形轴承 BEARING	1	

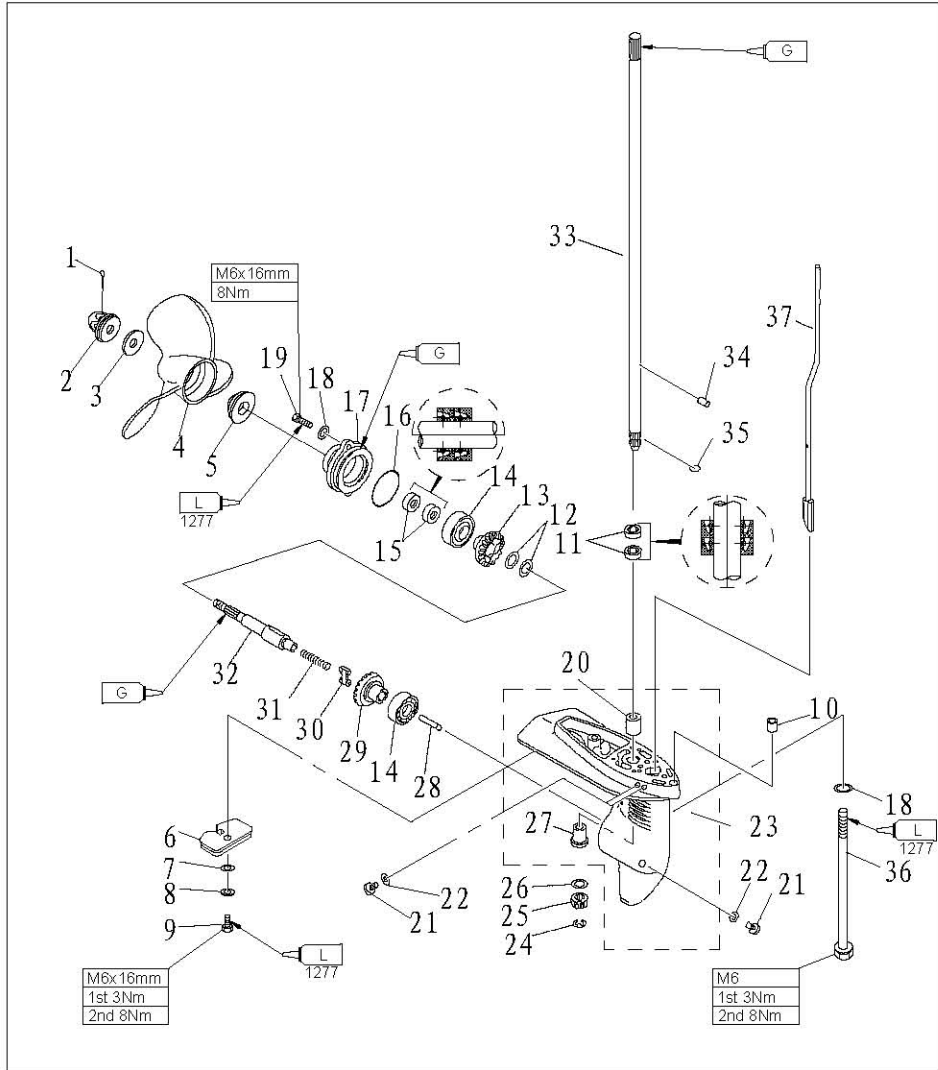

参照号码 SN.	零件编号 PART NO.	零件名称 DESCRIPTION	数量 QTY	备注 REMARKS
21	F4-03000023	注油孔螺塞 PLUG , OIL HOLE	3	
22	F4-03000024	注油孔螺塞垫圈 GASKET	3	
23	F4-03000001	水下装置壳体 LOWER CASING	1	
24	GB/T-896-86	开口档圈6 CIRCLIP	1	
25	F4-03000007	主动齿轮 INITIATIVE GEAR	1	
26	F4-03000006	主动齿轮垫圈 WASHER , INITIATIVE GEAR	1	
27	F4-03000002	带档边筒形轴承 BEARING	1	
28	F4-03000008	变档柱塞 PLUGER , SHIFT	1	
29	F4-03010000	正档齿轮组件 POSITIVE GEAR ASSY	1	
30	F4-03030002	离合器块 CLUTCH BLOCK	1	

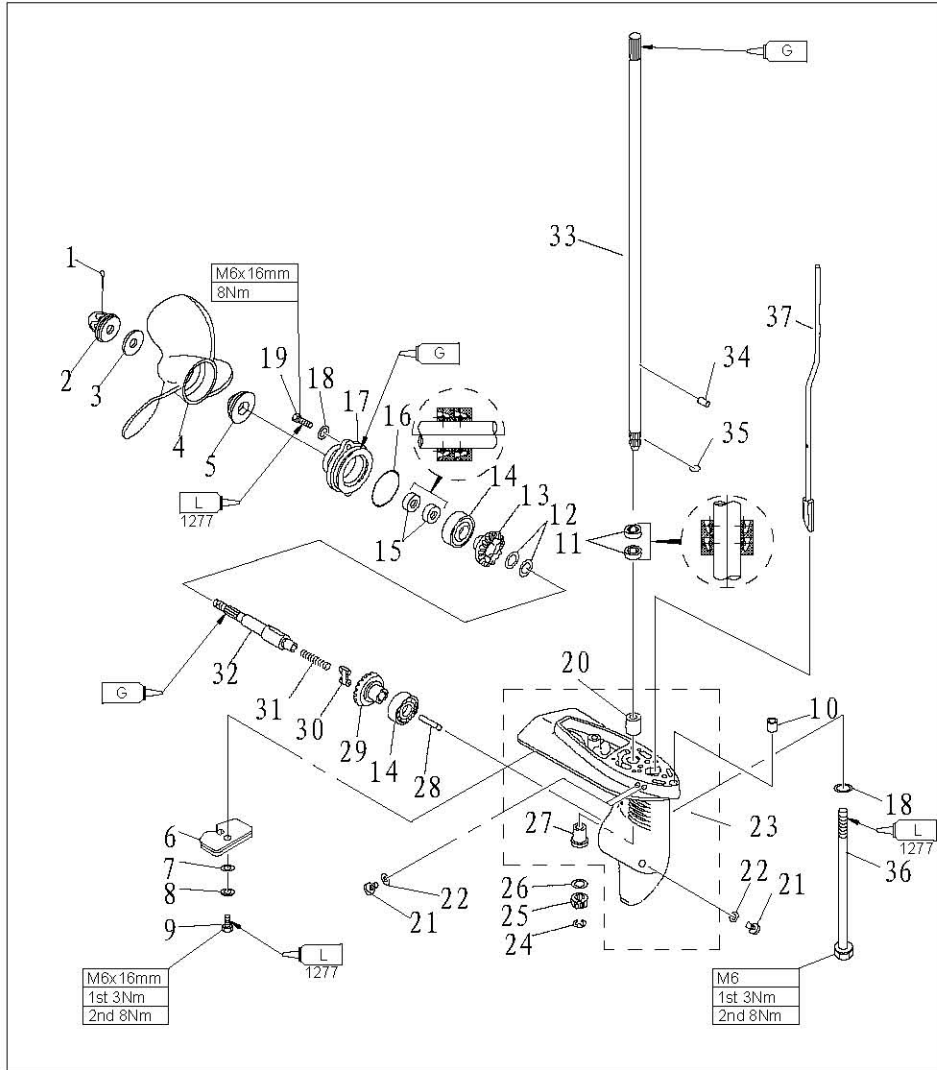

参照号码 SN.	零件编号 PART NO.	零件名称 DESCRIPTION	数量 QTY	备注 REMARKS
31	F4-03000003	离合器块压簧 SPRING ,CLUTCH BLOCK	1	
32	F4-03030001	螺旋桨轴 SHAFT ,PROPELLER	1	
33	F4-03000004	驱动轴 SHAFT ,DRIVE	1	L
	F4-03000004S	驱动轴 SHAFT ,DRIVE	1	S
34	F4-03000016	叶轮定位销 PIN	2	
35	F4-03000005	轴用钢丝档圈 CLIP	1	
36	GB/T5782-2000	六角头长螺栓M6×167 HEXAGON BOLT	2	L
	GB/T5782-2000	六角头长螺栓M6×40 HEXAGON BOLT	2	S
37	F4-03020000	变档凸轮组件 CAM ASSY ,SHIFT ROD		L
	F4-03020000S	变档凸轮组件 CAM ASSY ,SHIFT ROD		S

Disassembling and inspection

1. Remove cotter pin and nut assy.
2. Remove propeller assembly and spacer.
3. Remove the lower casing cover.

4. Remove the reverse gear assy, drive shaft, positive gear assy, and shift pluger.
5. Remove shift rod cam assy and drive shaft.
6. Remove barrel bearing with guard board (F4-03000002).
7. Remove barrel bearing without guard board (F4-03000003) by using barrel bearing installer tool.
8. Remove the clutch block from the propeller shaft.

Propeller shaft and clutch block

1. Check clutch block for wear or damage. Replace if necessary.
2. Check propeller shaft for wear or damage. Replace if necessary.

Clutch block installation

1. Put clutch block spring into the hole of the propeller shaft tail.
2. Install the clutch block as shown. Take note of the direction.

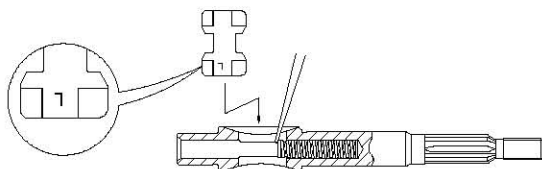

Lower casing cover

1. Check bearing for rust or rumbling when run. Replace if necessary.
2. Remove bearing and oil seal by bearing puller.
Note:
Don't remove bearing unless change it.
3. Clean casing cover by a soft brush and solvent.
4. Check casing cover for crack or damage. Replace if necessary.

Lower casing cover oil seal and bearing installation

1. Install oil seal.
2. Install bearing.

Note:

Please use special tool to install oil seal and bearing.
Pay attention to the oil seal installation direction and installation depth.
Make sure the manufacturer mark faces toward the reverse gear.

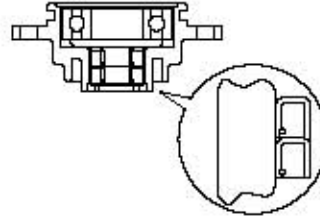

Barrel bearing

Inspect barrel bearing with guard board and barrel bearing without guard board for wear, crack or damage. Replace if necessary.

Drive shaft

Inspect the drive shaft for crank or wear. Replace if necessary.

Gear

Inspect the forward gear, reverse gear and mini gear for wear or damage. Replace if necessary.

Forward gear bearing

Inspect bearing for rust and rumbling when rotating. Replace if necessary.

Lower unit casing

1. Inspect lower casing cover for crack or damage. Check if the cooling water inlet is blocked. Replace if necessary.
2. Install the barrel bearing with guard board and barrel bearing without guard board by special tool.



Barrel bearing with guard board installer tool



Lower casing bracket and barrel bearing without guard board installer tool

3. Install new oil seal, with the depth as shown.
(unit: mm)



Lower casing bracket and drive shaft oil seal installer tool

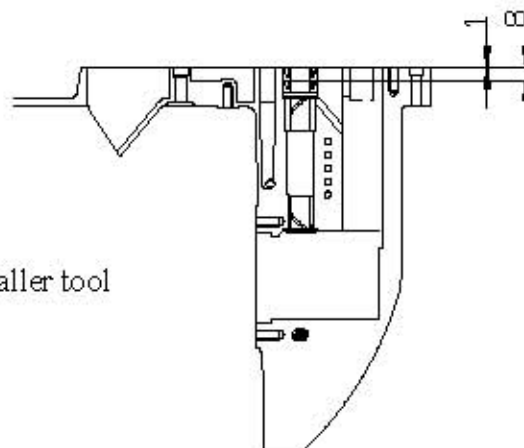

COMMON TROUBLES AND SOLUTIONS

Trouble type	Possible reason	Recovery action
Starter will not operate	Starter components are faulty	Repair or replace
	Shift level is not in neutral	Shift to neutral
Engine will not start (starter operates)	Fuel tank is empty	Fill tank with clean, fresh fuel
	Fuel is contaminated or stale	
	Fuel filter clogged	Replace fuel filter
	Fuel pump has malfunctioned	Repair or replace
	Air vent screw not loosened	Loosen air vent screw
	Spark plug(s) fouled or of incorrect type.	Inspect spark plug(s). Clean or replace with recommended type
	Spark plug cap(s) fitted incorrectly	Check and re-fit cap(s)
	Ignition wiring damaged or poorly connected	Check wires for wear or breaks. Tighten all loose connections. Replace worn or broken wires
	Ignition parts are faulty	Replace
	Engine stop switch lanyard is not attached	Attach lanyard
Engine inner parts are damaged	Repair	
Engine idles irregularly or stalls	Spark plug(s) fouled or of incorrect type.	Inspect spark plug(s). Clean or replace with recommended type
	Fuel system is obstructed	Check for pinched or kinked fuel line or other obstructions in fuel system
	Fuel is contaminated or stale	Fill tank with clean, fresh fuel
	Fuel filter clogged	Replace with recommended type
	Spark plug gap is incorrect	Inspect and adjust as specified
	Ignition wiring damaged or poorly connected	Check wires for wear or breaks. Tighten all loose connections. Replace worn or broken wires
	Specified engine oil is not being used	Check and replace oil as specified
	Thermostat is faulty or clogged	Replace
	Carburetor adjustments are incorrect	Replace
	Fuel pump is damaged	Replace
	Air vent screw on fuel tank is closed	Loosen air vent screw
	Fuel joint connection is incorrect	Connect correctly
	Choke knob is pulled out	Return to home position
Motor angle is too high	Return to normal operating position	

Cont'd

Trouble type	Possible reason	Recovery action
Engine power loss	Propeller is damaged	Repair or replace propeller
	Trim angle is incorrect	Adjust trim angle to achieve most efficient operation
	Motor is mounted at incorrect transom height	Adjust motor to proper transom height
	Boat bottom is fouled with marine growth	Clean boat bottom
	Weeds or other foreign matter are tangled on gear housing	Remove foreign matter and clean lower unit
	Spark plug(s) are fouled or incorrect type	Inspect spark plug(s). Clean or replace with recommended type
	Fuel system is obstructed	Check for pinched or kinked fuel line or other obstructions in fuel system
	Fuel filter is clogged	Replace with recommended type
	Fuel is contaminated or stale	Fill tank with clean, fresh fuel
	Spark plug gap is incorrect	Inspect and adjust as specified
	Ignition wiring is damaged or poorly connected	Check wires for wear or breaks. Tighten all loose connections. Replace worn or broken wires
	Ignition parts have failed	Replace
	Specified engine oil is not being used or oil is added too much	Check and replace oil as specified, or add engine oil to specified position
	Thermostat is faulty	Replace
	Fuel pump has malfunctioned	Replace
	Fuel joint connection is incorrect	Connect correctly
Specified spark plug(s) are not being used	Check and replace spark plug(s) as specified	
Engine vibrates excessively	Propeller is damaged	Repair or replace propeller
	Propeller shaft is damaged	Replace
	Weeds or other foreign matter are tangled on propeller	Remove and clean propeller
	Motor mounting bolt is loose	Tighten bolt
	Steering pivot is loose	Tighten steering pivot
	Steering pivot is damaged	Replace